

**VARIA ANATOLICA  
XIX**

# **SOCIÉTÉS HUMAINES ET CHANGEMENT CLIMATIQUE À LA FIN DU TROISIÈME MILLÉNAIRE : UNE CRISE A-T-ELLE EU LIEU EN HAUTE MÉSOPOTAMIE ?**

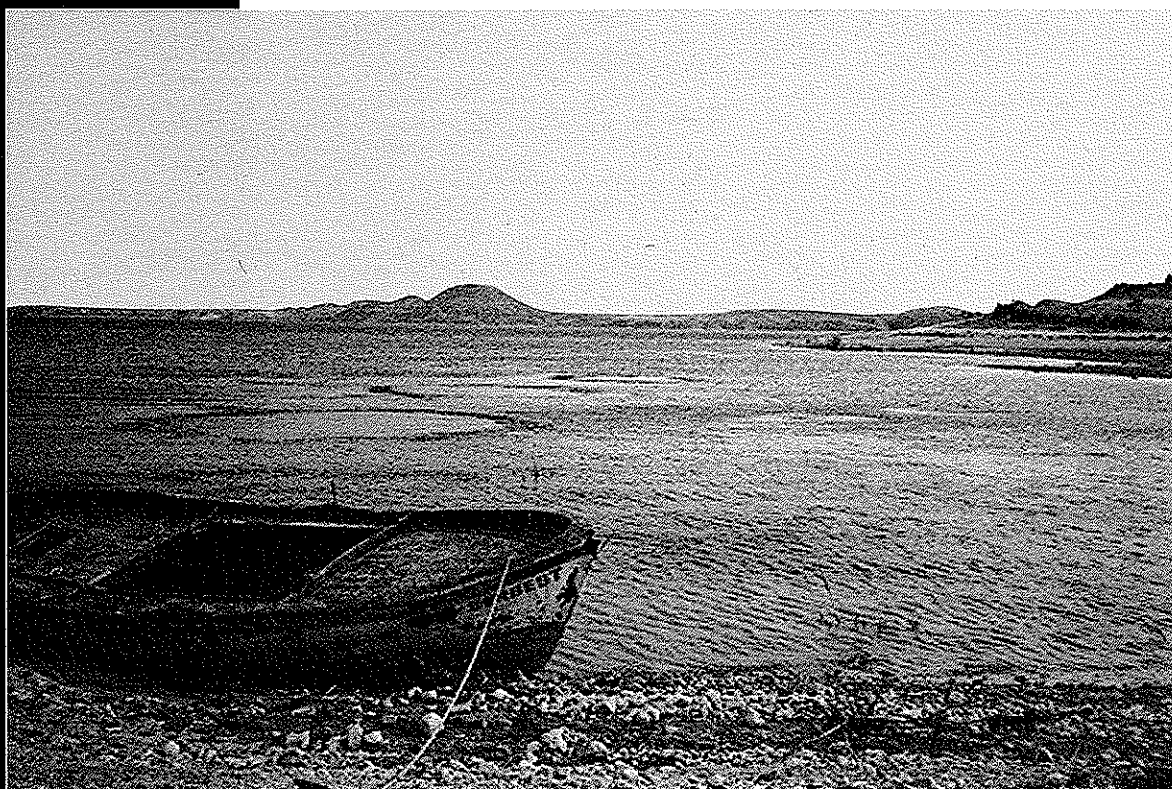

Institut français  
d'études anatoliennes  
Georges-Dumézil - Istanbul  
De Boccard

2007

**Actes du Colloque de Lyon,  
5-8 décembre 2005**

édités par  
**Catherine KUZUCUOĞLU et Catherine MARRO**

- 2002 : “The Ancient Bronze Age Pottery tradition in Northwestern Central Syria”, in M. al-Maqdissi, V. Matoïan et Ch. Nicolle (éds.), *Céramique de l’âge du Bronze en Syrie I. La Syrie du Sud et la Vallée de l’Oronte*, IFAPO, BAH / Institut français d’archéologie du Proche-Orient 161, Beyrouth : 69-96.
- 2005 : “Tell Afis, the survey and the regional sequence”, *Egitto e Vicino Oriente XXVIII* : 5-14.  
Métral, F.
- 2006 : “Transformations de l’élevage nomade et économie bédouine dans la première moitié du vingtième siècle”, in R. Jaubert et B. Geyer (éds.), *Les marges arides du Croissant fertile ; peuplements, exploitation et contrôle des ressources en Syrie du Nord*, Travaux de la Maison de l’Orient 43, Maison de l’Orient, Lyon : 81-101.  
Métral, J.
- 1993 : “Économies et sociétés : stratégies alternatives et cultures de l’aléatoire”, in R. Bocco, R. Jaubert et F. Métral (éds.), *Steppes d’Arabie : États, pasteurs, agriculteurs et commerçants : le devenir des zones sèches*, Cahiers de l’IUED, Genève, PUF, Paris : 381-387.  
Meyer, J-W.
- 2006 : “Zur Frage der Urbanisierung von Tell Chuera” in P. Butterlin, M. Lebeau, J.-Y. Monchambert, J.-L. Montero Fenollós and B. Müller (éds.), *Les espaces mésopotamiens : dimensions de l’expérience humaine au Proche-Orient ancien, volume d’hommage à J.-C. Margueron*, Subartu 17, Turnhout, Brepols : 179-189.  
Morandi Bonacossi, D.
- à paraître : “Tell Mishrifeh and its Region during the EBA IV and the EBA-MBA Transition: a first Assessment” in P. Parr (éd.), *The Levant in Transition - the Intermediate Early Bronze Age. Annual of the Palestine Exploration Fund*, W.S. Maney, London.  
Nigro, L.
- 2002 : “The Middle Bronze Age Pottery Horizon of the Northern Inner Syria on the Basis of the Stratified Assemblages of Tell Mardikh and Hama”, in M. al-Maqdissi, V. Matoïan et Ch. Nicolle (éds.), *Céramique de l’âge du Bronze en Syrie I. La Syrie du Sud et la Vallée de l’Oronte*, IFAPO, BAH 161, Institut français d’archéologie du Proche-Orient. Beyrouth, Damas, Amman : 97-128.  
Philip, G.
- 1989 : *Metal Weapons of the Early and Middle Bronze Ages in Syria-Palestine*. BAR-IS 526, Oxford.  
Schwartz, G., H.H. Curvers, F. A. Gerritsen, J.A. Maccormack, N. F. Miller and J. A. Weber
- 2000 : “Excavation and Survey in the Jabbul Plain, Western Syria : The Umm el-Marra Project 1996-1997”. *American Journal of Archaeology* 104/3 : 419-462.  
Thalmann, J.-P. (éd.)
- 2006 : *Tell Arqa-I ; Les niveaux de l’âge du Bronze*. BAH n° 177, Beyrouth.  
Vila, E. et M. El Basso
- 2006 : “Résultats préliminaires de l’étude de la faune d’Al-Rawda (Campagnes 2002 à 2004)”, *Akkadica* 126/2 : 111-119.  
Warburton, D.
- 2000 : “Synchronizing the Chronology of Bronze Age Western Asia with Egypt”, *Akkadica* 119-120 : 33-80.  
Wilkinson, T.
- 2000 : “Settlement and Land Use in the Zone of Uncertainty in Upper Mesopotamia” in R. M. Jas (éd.) *Rainfall and Agriculture in Northern Mesopotamia*, Nederlands Historisch-Archaeologisch Instituut te Istanbul, Leiden : 3-35.

Glenn M. SCHWARTZ\* and Naomi F. MILLER\*\*

## THE “CRISIS” OF THE LATE THIRD MILLENNIUM B.C.: ECOFACTUAL AND ARTIFACTUAL EVIDENCE FROM UMM EL-MARRA AND THE JABUL PLAIN

### Résumé

Cet article présente une relecture des données d’Umm-el-Marra (plaine du Jabbul, Syrie occidentale), relatives à la transition entre le Bronze Ancien et le Bronze Moyen susceptibles de contribuer à l’identification d’une crise pendant cette période. Des résultats d’analyses archéobotaniques, publiés pour la première fois, sont également discutés. À Umm-el-Marra, des changements sociaux, économiques et culturels coïncident avec un changement de la culture matérielle pendant la transition BA – BM ; dans certains cas, il semble plausible d’associer ces changements à une crise traversée par les sociétés locales complexes, mais d’autres interprétations sont également envisageables. Parmi celles-ci, il est possible que vers 2000 av. J.-C. Umm-el-Marra ait été abandonné de façon temporaire et que l’occupation la plus ancienne du Bronze Moyen soit d’extension relativement réduite. Le changement idéologique et politique est illustré par l’abandon des complexes mortuaires du Bronze Ancien final sur l’acropole du site, destinés à une élite, et par les modifications des pratiques mortuaires entre le Bronze Ancien et le Bronze Moyen. Des innovations économiques sont évidentes au Bronze Moyen dans l’accroissement significatif de la chasse d’espèces animales sauvages, particulièrement des équidés, pratique qui peut être interprétée comme une réponse à un milieu naturel ou social connaissant de fortes contraintes. Parallèlement à cette évolution, les données archéobotaniques indiquent une modification des pratiques liées au fourrage. Le déclin de l’occupation dans la partie semi-aride du Jabbul oriental pendant la transition BA – BM pourrait être interprété comme le révélateur d’une crise ; ce point cependant, tout comme les autres évoqués ici, nécessite d’être approfondi par de nouvelles recherches.

Since 1994, a joint Dutch-American expedition directed by Glenn Schwartz and Hans Curvers has conducted excavations at Tell Umm el-Marra, the largest Bronze Age site in the Jabbul plain (Fig. 1)<sup>1</sup>. Located between Aleppo and the Euphrates valley, the Jabbul probably served throughout history as a conduit between Mesopotamia and regions farther west. This liminal situation has been manifested by the material culture assemblages retrieved at Umm el-Marra, which contain traits common in both the Euphrates valley to the East and interior western Syria (e.g. Ebla) to the West. The Jabbul plain would have ostensibly supported a regime of dry farming, particularly in its rainier western regions, while pastoralist groups could utilize the drier regions to the East and Southeast<sup>2</sup>.

\*) The John Hopkins University, Baltimore, USA.

\*\*) University of Pennsylvania Museum, Philadelphia, USA.

1) Schwartz *et al.* 2000, 2003, 2006 ; Curvers and Schwartz 1997. The size of Umm el-Marra has been estimated at 25 ha, consisting of the walled enclosure of 20 ha plus a possible extension to the North under the modern village. In the later 1970’s and early 1980’s, a Belgian mission under the direction of Roland Tefnin also conducted a series of excavations at Umm el-Marra, documenting the Bronze Age and Hellenistic-Roman sequence (Tefnin 1983). In addition, Tefnin directed excavations at Tell Abu Danne, west of Umm el-Marra in the Jabbul region.

2) Rigot 2003 : Fig. 10 ; Wilkinson 2003 : Fig. 6.2.

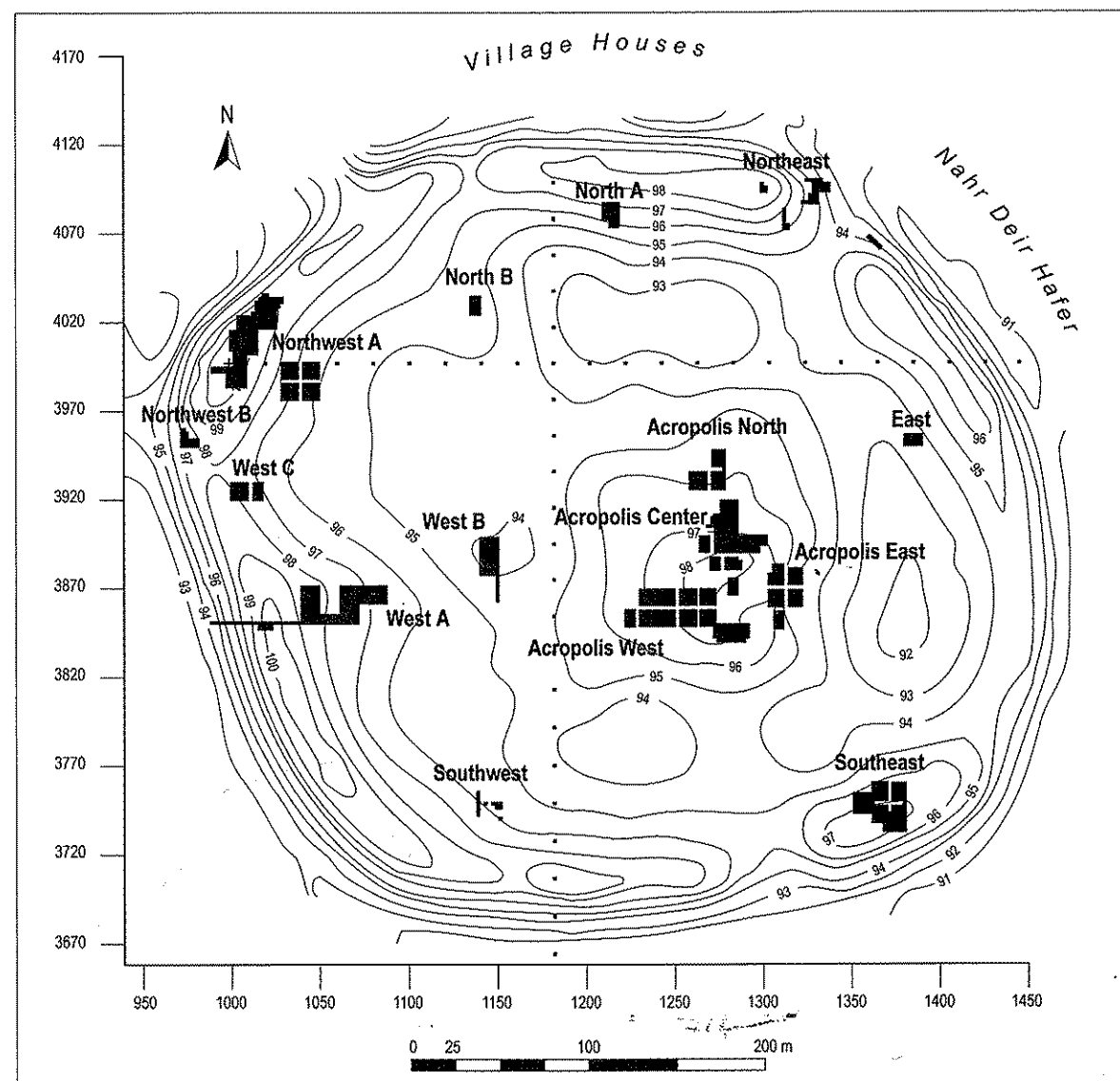

Fig. 1 : Tell Umm el-Marra.

Like many regions of western Syria and the Syrian Jezireh, the Jabbul saw a proliferation of sedentary occupation and an increase in societal complexity in the Third Millennium B.C.<sup>3</sup> The possibility of, and reasons for, a crisis or collapse in this urban society by the end of the millennium<sup>4</sup> has been a major focus of the Umm el-Marra project, as has the subsequent revival or regeneration of societal complexity in the early Second Millennium B.C.<sup>5</sup> By crisis or collapse, we primarily refer to the failure of centralized, urban-based and elite-run institutions; nonelite or non-sedentary individuals or institutions such as nomadic pastoral groups may survive or even prosper during such an episode of "collapse"<sup>6</sup>.

3) Akkermans and Schwartz 2003 : 233-87.

4) Weiss *et al.* 1993 ; Peltenburg 2000.

5) Schwartz *et al.* 2000, 2003 ; Schwartz 2006 ; Nichols and Weber 2006.

6) See Schwartz, this volume. As noted in that paper, symptoms of a decline in elite-dominated urban society might include partial abandonment or desertion of urban centers, a general decline in sedentary occupation, disintegration of large-scale political entities, breakdown of regional economic systems, and failure of civilizational ideologies.

As excavations proceed, our understanding of the data at Umm el-Marra has been continually modified, with new information requiring emendation of preexistent interpretations. In this paper, we briefly present our current appraisal of the relevant information, including a synopsis of chronological and artifactual data and a discussion of archaeobotanical results, incorporating a set of archaeobotanical data not previously reported<sup>7</sup>.

### EARLY BRONZE AGE OCCUPATION

The eras relevant to a consideration of the late Third Millennium "crisis" or collapse are, in local terms, the Early and Middle Bronze periods, which span, very approximately, the entirety of the Third Millennium and the first half of the Second Millennium in western Syria. At Umm el-Marra, excavations have revealed a long Bronze Age sequence (Table 1). The earliest period of occupation

Table 1 : Umm el-Marra Relative Chronology.

Chronological Period	Umm el-Marra Period	Absolute Date
Roman	Ia	ca. 50 B.C.-400 AD
Achaemenid/Hellenistic	Ib	ca. 500-50 B.C.
Late Bronze Age	II	ca. 1600-1200 B.C.
Middle Bronze II (Mardikh IIIB)	IIa-c	ca. 1800-1600 B.C.
Middle Bronze I (Mardikh IIIA)	IIId	ca. 2000-1800 B.C.
Early Bronze IVB (Mardikh IIB2)	IV	ca. 2300-2000 B.C.
Early Bronze IVA (Mardikh IIB1)	V	ca. 2450-2300 B.C.
Early Bronze III	VI, late	ca. 2600-2450 B.C.
Early Bronze II	VI, early	ca. 2800-2600 B.C.

at the site thus far revealed, which is documented in limited soundings on the Umm el-Marra acropolis, dates to the earlier Third Millennium B.C., perhaps the second quarter of the millennium (= Umm el-Marra period VI, early). Although the subdivisions of the Early Bronze period prior to EB IV are vaguely defined, at best, in western Syria, this early occupation might be tentatively associated with the period designated Early Bronze II<sup>8</sup>. Ceramic parallels with assemblages like that of Qara Quzaq level V in the Euphrates valley can be observed<sup>9</sup>.

The succeeding phase (Umm el-Marra VI, late), attested by a larger excavation sample on the acropolis, is probably to be associated with the EB III period in the middle of the Third Millennium B.C.<sup>10</sup> Samples of diverse architecture were obtained on the Acropolis (Center, North, and East excavations), the most prominent of which is a set of monumental, ostensibly elite tombs in the Acropolis Center (Tombs 5, 6, and 8)<sup>11</sup>. The pottery assemblage of this phase includes painted Euphrates Banded Ware, "Champagne" vessels, open forms with thin or thick beaded rims, often with a slightly inverted upper body, short flat-based corrugated cups, jars with curving, everted necks, sometimes with an interior thickening or bead at the rim as if to accommodate a lid, and simple rim cooking pots with necks that are either short and vertical or tall and flaring.

Elite tombs on the Acropolis Center (*cf.* Tombs 1, 3, 4) as well as associated installations with the remains of sacrificed equids continued to be erected in Umm el-Marra period V (= Early Bronze IVA), assignable to the third quarter of the millennium. Small-scale architecture is also attested in the Acropolis Center, East, and West. On the western edge of the site in West Area A, excavations have revealed the existence of an earthen community enclosure wall that is datable to this period, if not also earlier, since a two-chamber updraft kiln with EB IVB (or late EB IVA) pottery was dug into it<sup>12</sup>. The pottery of Umm el-Marra period V includes material comparable to Mardikh IIB1,

7) In this paper, Miller presents the archaeobotanical data and their interpretation, while Schwartz provides the remaining discussion. The authors are grateful to Jill Weber for provision of a summary of her faunal data.

8) Mazzoni 2002.

9) Valdés Pereiro 1994, 2001.

10) Mazzoni 2002. A partial correlation with Mazzoni's EB IVA1 period is also conceivable, but a more comprehensive definition of both phases is needed. It is to be hoped that the subdivisions of the Third Millennium will be more precisely defined by the ARCANÉ project of the European Science Foundation, currently in progress.

11) Schwartz *et al.* 2006.

12) Waster sherds found inside the kiln included vertical rim bowls with collared rims (of the type illustrated in Schwartz *et al.* 2003 : Fig. 23 : 3) and tall corrugated caliciform "Hama" goblets. A complete small gray spiral-burnished goblet was also found inside the structure.

Amuq I, Hama J 8-5, and Early Selenkahiyeh, with tall ring-based corrugated "Hama" goblets<sup>13</sup>, gray spiral-burnished "Syrian bottles"<sup>14</sup>, tall-necked collared rim jars<sup>15</sup>, and bowls with thickened triangular rims<sup>16</sup>.

Following this phase is Umm el-Marra period IV (=Early Bronze IVB), approximately datable to the last quarter of the Third Millennium. In the Acropolis Center, Tomb 7, a disturbed and largely emptied multi-chambered structure cutting into the preexisting Tomb 6, contained complete vessels that may either be dated to period IV or to late period V<sup>17</sup>. Otherwise, period IV includes small-scale architecture on the Acropolis Center and domestic architecture and evidence of craft production in the Acropolis North, East and West. The potter's kiln noted above in West Area A contained ceramics probably to be assigned to this phase. This feature was dug into an earlier earthen rampart, implying that at least in this part of the site, the earlier fortifications were no longer in use or that a kiln could be dug into in them while they still functioned. The pottery of period IV resembles that of Mardikh IIB2, Amuq J, and Late Selenkahiyeh, with such diagnostics as occasional painted and incised caliciform "Hama" goblets, vertical rim bowls with collared and sometimes grooved rims, goblets with collared rims, coarse brown platters with pitted bases, and Smear Wash Ware.

Given the above data, we may tentatively conclude that mid-late Third Millennium B.C. Umm el-Marra was a large, fortified regional center<sup>18</sup> centered around an elite mortuary complex on an elevated position dominating the site landscape. The latter feature implies the presence of an ostentatious elite that probably legitimized its authority through rituals of ancestor veneration<sup>19</sup>.

Complicating this picture is the evidence from soundings conducted in 2006 between the acropolis and the city wall area in West Area A and North Area B, where a sequence of MB phases was underlain by a thin layer with EB III-IV sherds deposited above virgin soil<sup>20</sup>. While such results might suggest that certain areas between the site's outer edge and the acropolis were only minimally utilized in the Third Millennium, it is also conceivable that EB deposits in these areas had been removed for use in MB glacis constructions built on the site edge; the glacis material excavated in the West Area A was replete with EB sherds, clearly indicating that the soil had been derived from a location on the site with EB deposits that had been dug up for employment in the glacis<sup>21</sup>.

### THE TRANSITION FROM EARLY TO MIDDLE BRONZE

It is clear that major material culture change took place at Umm el-Marra in the shift from EB to MB (period IV to III), a development particularly manifested by significant innovations in ceramic shapes, wares, and technology. In general, the period III (MB) pottery is thicker-walled and coarser than period IV (EB), with fewer ware categories and even less effort expended on decoration (mainly comb incision, occasionally painting) than was in the case in EB (e.g. spiral burnishing, corrugation, painting). An increased emphasis on ceramic mass manufacture is also observable, illustrated by, for example, the production of cooking vessels on the wheel, as opposed to hand manufacture as in EB<sup>22</sup>.

13) Schwartz *et al.* 2006, Fig. 21: 13, 15-16.

14) Schwartz *et al.* 2006, Fig. 21: 4-5.

15) Schwartz *et al.* 2006, Fig. 21: 6-7.

16) Schwartz *et al.* 2006, Fig. 16: 16-19.

17) These include vertical rim bowls with collared rims and tall caliciform Hama goblets. Sherds of clear EB IVB type were found in the debris of the tomb above the tomb floors; while they might be fragments of vessels from the tomb's original contents that had been broken when the tomb was disturbed, it is also possible that the sherds date to the period when the tomb became filled with debris subsequent to its use.

18) Evidence of an earthen wall or freestanding rampart like that exposed in West Area A was identified in a sounding in Northwest Area A; the Belgian excavations tentatively identified an EB city gate in the northeast (Tefnin 1983).

19) Schwartz *et al.* 2003, 2006; Schwartz in press.

20) The results from a sounding to virgin soil in West Area B in 1994 may also indicate a similar pattern of minimal EB deposits underneath second-millennium strata, although the area was much disturbed by the intrusion of a vast Late-Bronze period pit (Curvers and Schwartz 1997: 217).

21) A similar scenario has been proposed at Ebla (Matthiae 1997) and at Tel Dan in northern Palestine (D. Ilan, personal communication).

22) On wheelmade cooking ware in MB Syria, see Mason and Cooper 1999: 135-47.

In previous publications, we have considered whether this material culture transformation was coincident with collapse or other major social change at Umm el-Marra in the late Third Millennium B.C. In particular, we have examined the possibility of a gap in site occupation after period IV and a reduction in the area of site occupation in the earliest phases of period III<sup>23</sup>. The evidence as currently available is summarized below.

### Evidence for an Occupational Break

There is no layer of sterile soil separating EB from MB strata<sup>24</sup>, but the possibility of an occupational hiatus is suggested by the ceramic data, given the apparent absence of a phase dating to the very beginning of MB at the site. Although there is no relatively close site having a well-published, continuous stratified sequence spanning the EB to MB transition, comparanda with diverse sequences in northern Syria suggest the possibility of an occupational break.

The earliest MB phase at Umm el-Marra is designated as sub-period IIIId, first identified in 1997 as the two earliest strata in the long MB sequence in the Acropolis West, comprising small-scale, apparently domestic architecture. These contexts yielded a pottery corpus missing some of the more common types from later MB strata and featuring some types that were less frequent in later MB. Among the more frequent types in the assemblage were shallow carinated bowls with triangular rims (Fig. 2: 3,4,7), goblets with a biconical shape and everted bead rim (Fig. 2: 11,13), and large closed vessels with a thick everted rim and a horizontal raised ridge below the neck (Fig. 3: 1-5,7). Also attested were open and closed forms with flat or ledge rims with grooving on top (Fig. 2: 1,10; Fig. 4: 2,4-9), large, slightly restricted forms with tall, ridged necks and flat rims (Fig. 4: 1,3) and tall-necked jars with grooved rims<sup>25</sup>. Comb-incised decoration was sometimes employed, including a design composed of alternating horizontal registers of undulating lines, horizontal bands, and diagonal patterns (Fig. 3: 10)<sup>26</sup>.

Although relatively rare, painted pottery was attested in sub-period IIIId (Fig. 4: 10-14) and is usually identifiable as belonging to the Syro-Cilician painted ware assemblage attested at Alalakh (levels XVII-VIII) and Ebla. The jug or juglet with painted horizontal stripes on the upper body and groups of vertical stripes below the shoulder (Fig. 4: 10,14) is also attested at Hama level H5 (early MB) and at Tell Khamis in the Tishrin salvage region of the middle Euphrates<sup>27</sup>. In sub-period IIIId, the most common cooking vessel has an angular everted rim<sup>28</sup>, a type that becomes less frequent in later MB, when the cooking jar with collared rim makes its appearance<sup>29</sup>.

Most of the Umm el-Marra IIIId types enumerated above do not completely disappear in subsequent levels but are also observable with some frequency in later MB contexts (Umm el-Marra IIIa-c). Conversely, some types that are particularly characteristic of later MB, like the bowl with inturned rim<sup>30</sup>, are not completely unattested in earlier MB contexts<sup>31</sup>. Given this stylistic continu-

23) Schwartz *et al.* 2000, 2003.

24) While erosion layers may be characteristic of occupational breaks, they may not necessarily be present given the vagaries of site formation processes and the activities of later inhabitants. At Umm el-Marra, Achaemenid/Hellenistic levels are often deposited directly above Late Bronze levels without stratigraphic evidence of a period of abandonment.

25) For comparable shapes, see Nigro 2002: Fig. 49, 46-50.

26) Note that the same motif appears at Abu Danne level VI (Tefnin 1980: plate 8, 10), Lidar MB phase 1, the earliest MB phase identified (Kaschau 1999: tafel 26: 2-3,5-8), Qara Quzaq phases II-1 and II-2 (Valdés Pereiro 1994: Fig. 9: 4, Fig. 10: 10-11, Fig. 11: 12; Valdés Pereiro 2001: Fig. 8: 1; Fig. 25: 18-19), and in a deep sounding at Emar (phase OSO 8, the third MB phase identified (Finkbeiner and Sakal 2003: abb. 15: f,h).

27) Fugmann 1958: Fig. 109, 3H 197. A specimen from Tell Khamis is on display in the Aleppo Museum.

28) Curvers and Schwartz 1997: Fig. 24: 7 (an MB II example).

29) Curvers and Schwartz 1997: Fig. 24: 15.

30) Curvers and Schwartz 1997: Fig. 24: 5-6.

31) A similar pattern is attested at Ebla, where inturned rim bowls occur first in MB I but are especially profuse in MB II, while carinated bowls are characteristic of MB I but continue well into MB II (Nigro 2002). It should be noted, however, that some types popular in the latest MB strata at Umm el-Marra have no attestations in the earlier MB strata, like the "shoulder goblet" (Curvers and Schwartz 1997: Fig. 23: 10), the wide-mouthed tall-necked large jar, often with corrugated or painted decoration on the neck (Curvers and Schwartz 1997: Fig. 23: 15), or the beaker with low carination (Curvers and Schwartz 1997: Fig. 23: 17).

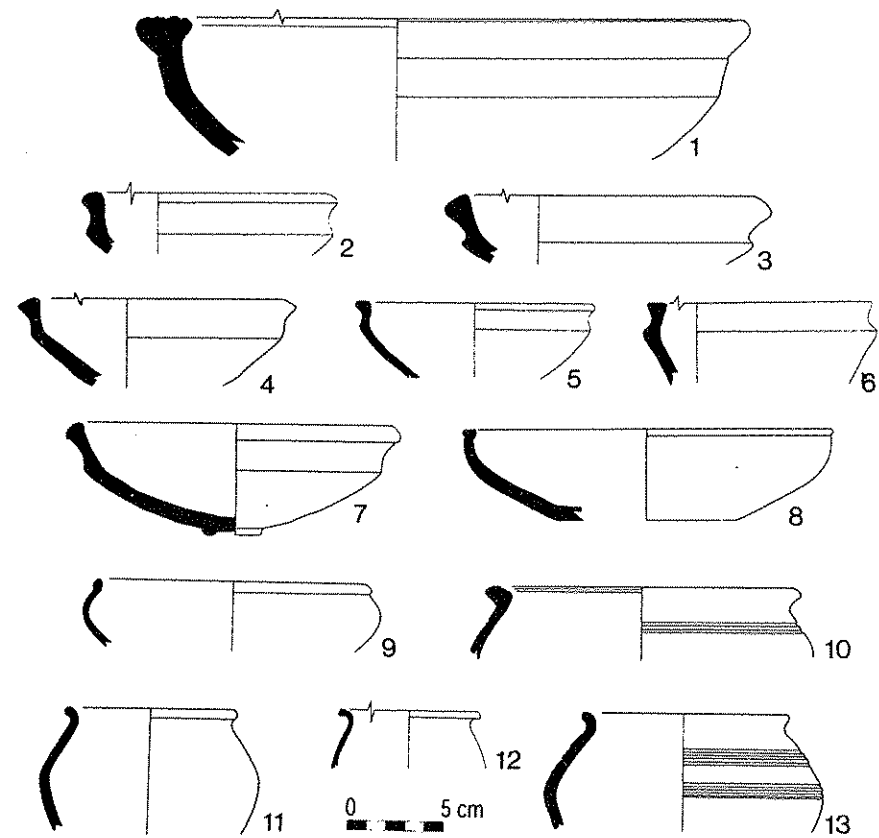

Fig. 2 : MB I (Umm el-Marra IIIc) pottery.

1. Light yellow-green exterior (slip?), light brown interior/core, fine sand, wheelmade. Acropolis West unit 1228/3860.
2. Light yellow, fine black sand, wheelmade. Acropolis West unit 1228/3872.
3. Light yellow/green, fine sand and chaff, wheelmade. Acropolis West unit 1228/3860.
4. Light yellow exterior slip core/interior red and brown, fine/medium white sand, wheelmade. Acropolis West unit 1228/3860.
5. Light yellow-green, fine sand, wheelmade. Acropolis West unit 1228/3872.
6. Light yellow exterior/interior (slip?), core yellow/brown/yellow "sandwich", fine sand and medium chaff. Acropolis West unit 1228/3872.
7. Carinated complete bowl with ring base. Light brown to red, fine sand, wheelmade. Acropolis West unit 1228/3860.
8. Light pink exterior/interior, core light brown, fine sand, wheelmade. Acropolis West unit 1228/3860.
9. Light brown exterior/interior, core light brown/grey/light brown "sandwich", fine black and white sand, wheelmade. Acropolis West unit 1228/3860.
10. Light yellow- slip exterior, pink core/interior, fine white sand, wheelmade, comb incised. Acropolis West unit 1228/3860.
11. Light yellow, no visible temper, wheelmade. Acropolis West unit 1228/3860.
12. Light yellow, fine sand, wheelmade. Acropolis West unit 1228/3872.
13. White/yellow interior exterior/interior slip, core yellow-brown, fine sand, wheelmade, comb incised. Acropolis West unit 1228/3860.

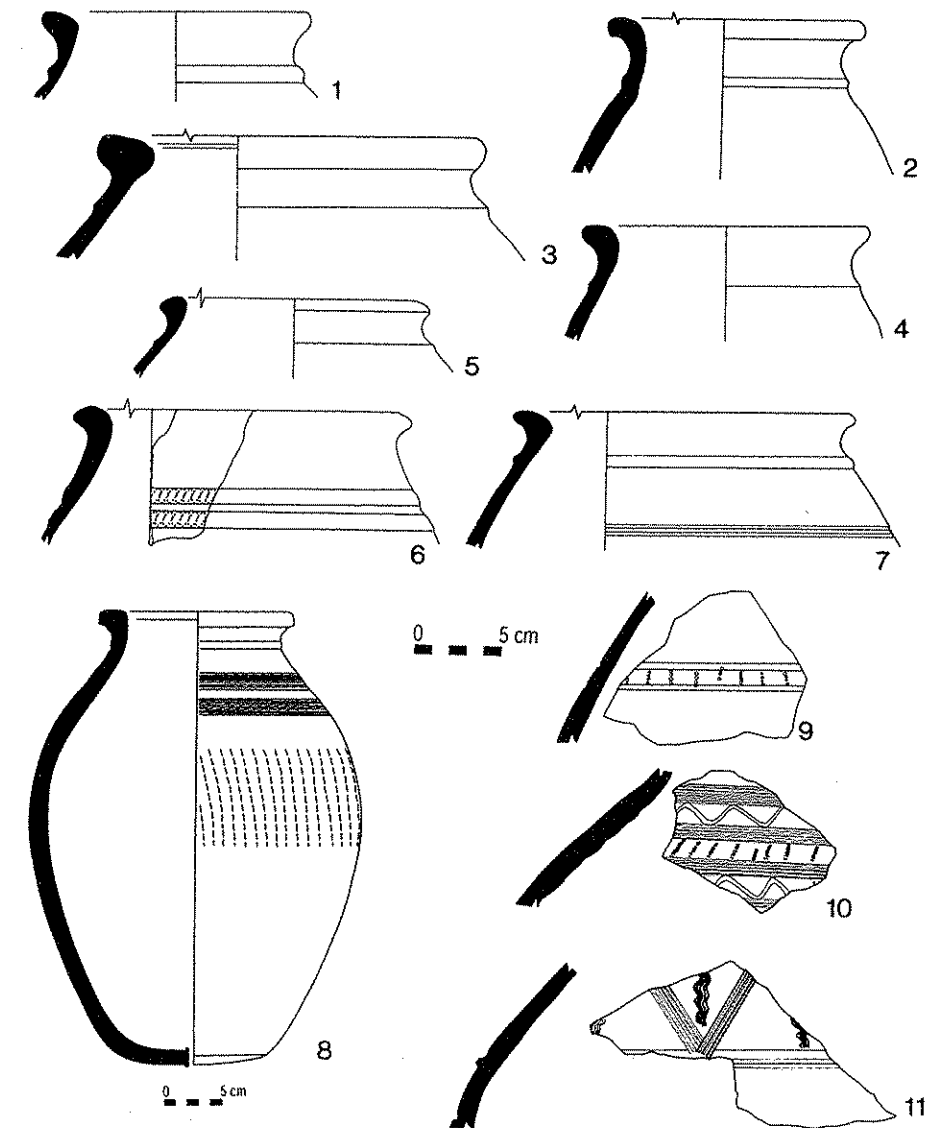

Fig. 3 : MB I (Umm el-Marra IIIc) pottery.

1. Light yellow slip exterior/interior, core brown, fine sand, wheelmade. Acropolis West unit 1228/3860.
2. Light pink exterior/interior, grey core, fine/medium chaff. Acropolis West unit 1228/3860.
3. Light yellow slip exterior, light brown and pink core/interior, fine/medium sand and lime, wheelmade. Acropolis West unit 1228/3860.
4. Yellow-brown slip exterior, core/interior light brown, fine white sand and lime, wheelmade. Acropolis West unit 1228/3860.
5. Red exterior/interior, red-brown core, fine sand, wheelmade. Acropolis West unit 1228/3872.
6. Grey, coarse, white sand, thumb-impressed *appliqué*. Acropolis West unit 1228/3872.
7. Light grey, no visible temper, wheelmade, comb incised. Acropolis West unit 1228/3860.
8. Light yellow to grey exterior (slip?), core and interior light brown, fine/medium lime, wheelmade, perforated base, comb incised, traces of light scraping on upper body in parallel oblique lines. Acropolis North unit 1270/3936, containing baby skeleton.
9. Brown cookware, fine white sand, wheelmade, incised. Acropolis West unit 1228/3860.
10. Light yellow, fine sand, wheelmade, comb incised with punctate incision (7-8 marks each). Acropolis West unit 1228/3860.
11. Light yellow slip ware exterior, light brown interior/core, fine sand, wheelmade, comb incised. Acropolis West unit 1228/3860.

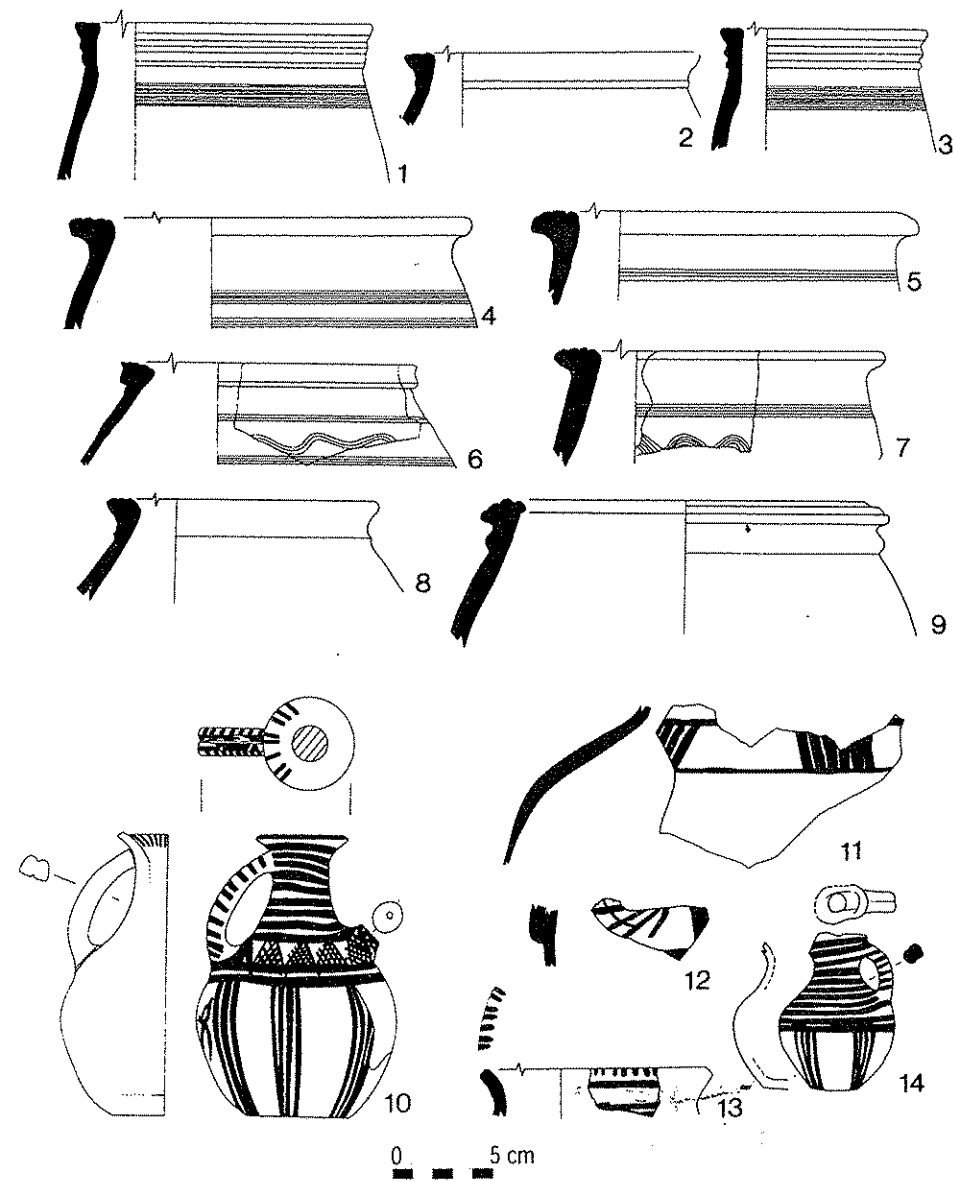

Fig. 4 : MB I (Umm el-Marra IIIId) pottery.

1. Light yellow, fine sand, wheelmade, comb incised. Acropolis West unit 1228/3872.
2. Grey exterior, brown interior, core brown, fine sand, wheelmade. Acropolis West unit 1228/3872.
3. Light yellow exterior/interior, core white, fine sand, wheelmade, comb incised. Acropolis West unit 1228/3872.
4. Light yellow, fine sand and chaff, wheelmade, comb incised. Acropolis West unit 1228/3860.
5. Light yellow exterior/interior, core light brown, fine sand, comb incised. Acropolis West unit 1228/3872.
6. Light yellow exterior (slip?), pink-yellow interior, core pink-brown, fine sand, comb incised, wheelmade. Acropolis West unit 1228/3872.
7. Light yellow to pink, fine sand, wheelmade, comb incised. Acropolis West unit 1228/3872.
8. Light yellow exterior slip, light pink-yellow core/interior, fine sand, wheelmade. Acropolis West unit 1228/3860.
9. Light green, fine sand, wheelmade. Acropolis West unit 1228/3860.
10. Light brown, medium sand, dark brown paint. Acropolis North unit 1270/3926, associated with baby burial.
11. Pink-brown, fine lime, some chaff, wheelmade, brown paint. Acropolis West unit 1228/3860.
12. Light pink exterior/interior, core pink/brown/pink "sandwich", fine white sand, red paint (2 segment strap handle). Acropolis West unit 1228/3860.
13. Brown-yellow exterior slip, core/interior brown, fine white sand, wheelmade, dark brown paint. Acropolis West unit 1228/3860.
14. Light pink-brown, fine dark sand, brown paint. Acropolis West unit 1228/3860.

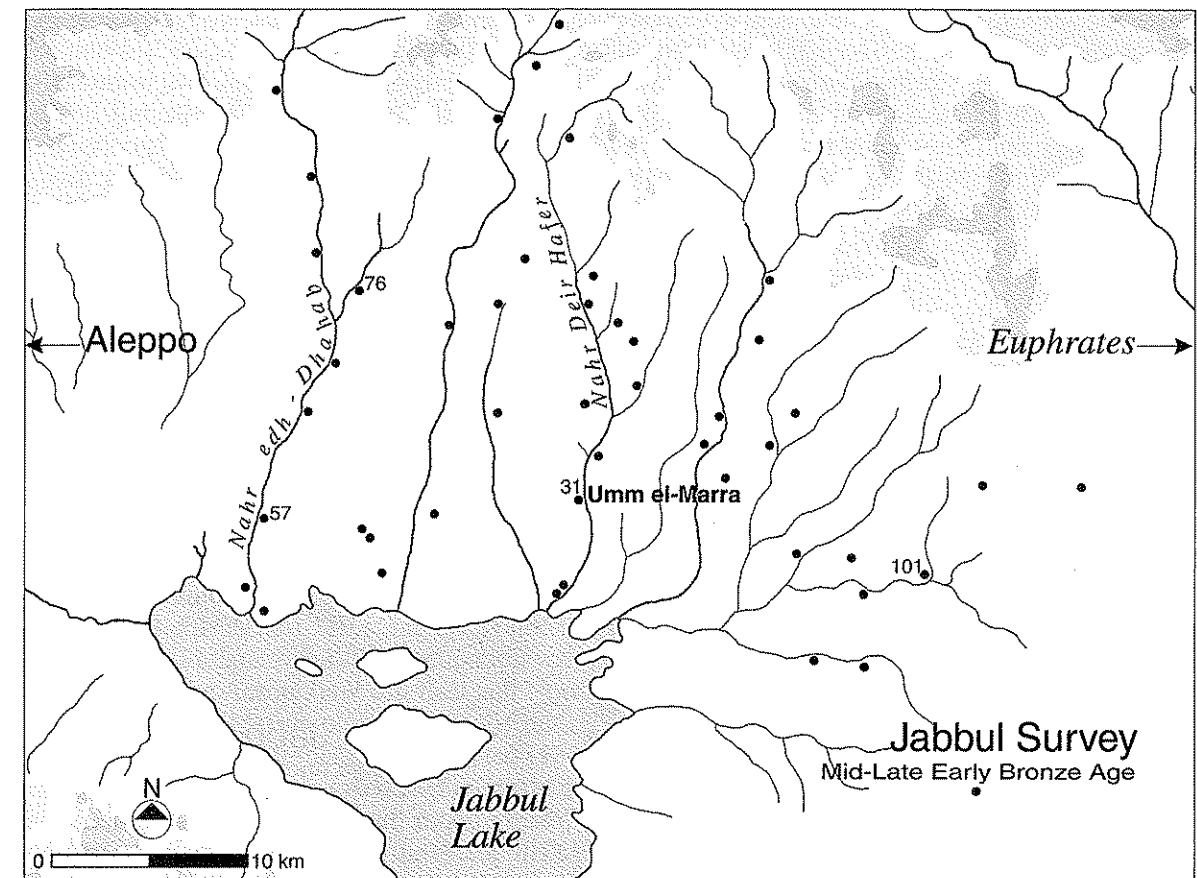

Fig. 5 : Mid-late Early Bronze Age site distribution, Jabbul 1996 survey.

ity between IIIId and IIIa-c, the identification of a given assemblage as IIIId or IIIa-c elsewhere on the site is best accomplished through a consideration of relative frequencies of ceramic types.

While regional differentiation may complicate attempts at cross-dating, one can observe that the Umm el-Marra IIIId assemblage is most comparable to pottery from contexts understood as later MB I, or, more rarely, early MB II, in the terms proposed by Matthiae for the Ebla chronology<sup>32</sup>. These include Ebla IIIA2 (MB IB)<sup>33</sup>, Hammam et-Turkman VIIB<sup>34</sup>, Halawa Tell A level Q2<sup>35</sup>, Qara Quzaq

32) Matthiae 1997 ; Akkermans and Schwartz 2003 : 291-2.

33) After reviewing drawings of the Umm el-Marra IIIId pottery, Lorenzo Nigro (personal communication), who analyzed the Ebla III ceramics, noted abundant similarities to the pottery from Ebla IIIA2 (MB IB) and only a few comparable to Ebla IIIA1 (MB IA). Compare Fig. 2: 5 with Nigro 2002 : plate 48: 39, and Fig. 2: 13 with Nigro 2002 : plate 48: 27. Fig. 4: 7 compares with Nigro 2002 : plate 47, 20 (MB IA, but this type persists throughout Ebla MB, for which see Pinnock 2005 : plate 28).

34) For Hammam VIIB parallels to Umm el-Marra IIIId, compare Fig. 2 : 4 with Curvers 1991 : plate 20, 7034, plate 21, 7035 ; Fig. 2: 6 with Curvers 1991 : plate 20, 7031, plate 22, 7282 (cf. also Hammam VIIA plate 16, 7032, 7040) ; Fig. 2: 7 with Curvers 1991 : plate 21, 7046 ; Fig. 3: 11 with Curvers 1991 : plate 22, 7063 ; and Fig. 4: 2 with Curvers 1991 : plate 23, 7089 (but no ridges atop rim). Hammam VIIB succeeds the earliest MB phase at the site, VIIA, and includes MB I types like carinated bowls as well as MB II types like bowls with inturned rims, shoulder goblets, and beakers with low carination. Also from the Balikh region, see parallels from the Middle Bronze sequence at Bi'a, e.g. compare Fig. 2: 4 with Einwag 1998 : abb. 51: 1 (KK 6), also types 32 and 42 ; Fig. 2: 11 with Einwag 1998 : abb. 51: 6 (KK 6) and type 54 ; and Fig. 4: 1,3 with Einwag 1998 : type 137 (most common in KK 6-7). The majority of the Bi'a parallels are most common in the late MB I/early MB II phases KK 6-7, KK7 being contemporaneous with tablets from the reign of Iasmah-Addu.

35) For parallels, compare Fig. 2: 11 with Hempelmann 2005 : tafel 85, 532, 535 ; Fig. 3: 7 with Hempelmann 2005 : tafel 91, 579 ; Fig. 3: 8 with Hempelmann 2005 : tafel 90, 574 (upper body only) ; and Fig. 4: 4 with Hempelmann 2005 : tafel 90, 577.

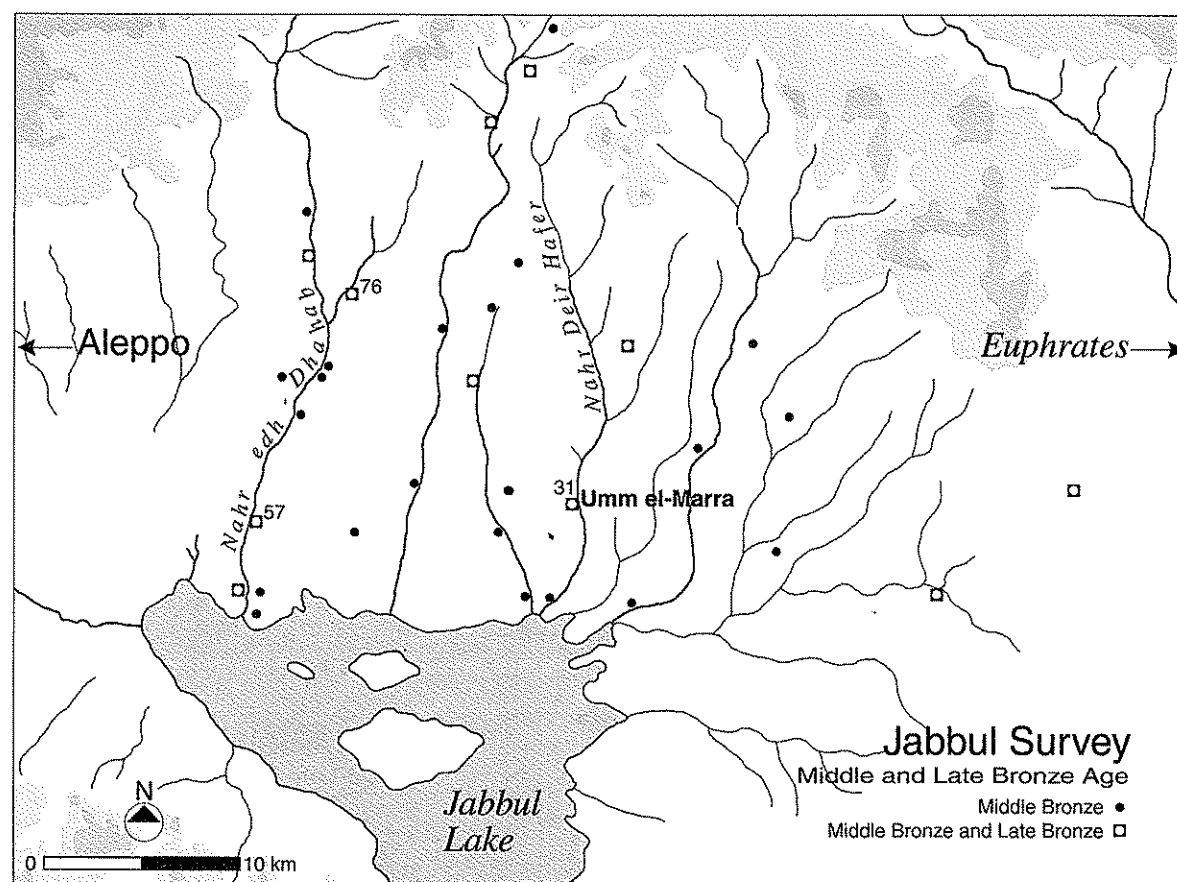

Fig. 6 : Middle and Late Bronze Age site distribution, Jabbul 1996 survey.

phases II-1 and II-2<sup>36</sup>, and Hadidi MB IIA-B<sup>37</sup>. The appearance of Syro-Cilician painted pottery in the earliest sub-period IIIId strata might also indicate a later MB I date, since the *floruit* of that style is later MB I/early MB II<sup>38</sup>.

The above comparanda suggest that Umm el-Marra IIIId, the earliest MB phase at the site, is assignable to a later MB I time frame and that Umm el-Marra IIIa-c can be assigned to MB II. If this

36) For parallels, compare Fig. 3: 4-5 with Valdés Pereiro 2001 : Fig. 23: 15 (phase II-1) ; Fig. 3: 7 with Valdés Pereiro 2001 : Fig. 23: 17 (phase II-1) ; and the combed motif cited in note 26 (phases II-1 and II-2).

37) For parallels, compare Fig. 3: 2 with Dornemann 1992 : fig. 3: 20 (MB IIB) ; Fig. 4: 2 with Dornemann 1992 : fig. 4: 14, fig. 5: 4 and 8 (MB IIB) ; Fig. 4: 8 with Dornemann 1992 : fig. 4: 15, fig. 5: 8 (MB IIB) ; and Fig. 4: 9 with Dornemann 1992 : fig. 19: 4 (MB IIA). Note that E. Cooper (1997 : 175) places Dornemann's MB IIA and MB IIB in a phase representing the middle of the Hadidi MB sequence ; Umm el-Marra IIIId pottery has many parallels with pottery presented by Cooper from the same phase (for our Fig. 2: 1, see Cooper 1997 : 136, fig. 21, type O1 ; for Fig. 2: 4, see Cooper 1997 : 136, fig. 21, type O2 ; for Fig. 2: 11,13, see Cooper 1997 : 120, fig. 5, type C1 ; for Fig. 3: 2, see Cooper 1997 : 133, fig. 18, type C24e ; for Fig. 3: 5, see Cooper 1997 : 125, fig. 10, type C14a ; for Fig. 4: 2,8, see Cooper 1997 : 124, fig. 9, type C13a). For parallels with the Emar MB deep sounding, compare Fig. 2: 11 with Finkbeiner and Sakal 2003 : fig. 15a (OSO phase 8) and Fig. 4: 1,3 with Finkbeiner and Sakal 2003 : fig. 17d (OSO phase 10, earliest phase documented), as well as the combed motif cited in note 26 above. Although at some remove from our area, parallels from earlier MB phases at Lidar Höyük in the Karababa region of the Turkish lower Euphrates can be cited for our Fig. 2: 4 (Kaschau 1999 : tafel 71: 5 phase 2/3), Fig. 2: 11 (Kaschau 1999 : tafel 20: 5,7,11 phase 1 ; tafel 55: 5,15 phase 2), Fig. 2: 13 (Kaschau 1999 : tafel 20: 21 phase 1 ; tafel 95: 1 phase 3), Fig. 3: 7 (Kaschau 1999 : tafel 75: 6, tafel 84: 5 phase 3), Fig. 4: 3 (Kaschau 1999 : tafel 3: 1 phase 1), and the combed motif noted above.

38) Bagh (2003 : 234-5) suggests that Syro-Cilician painted ware appeared later than Levantine Painted and Khabur wares. Nigro (2002a, 104), however, maintains that Syro-Cilician painted ware emerged at the very beginning of MB, while averring that its *floruit* is late MB I. See Gates 2000 for MB II examples.

is correct, then the excavated deposits at Umm el-Marra have no evidence of occupation in early MB I. Likewise, one can observe that Umm el-Marra does not have an EB-MB "transitional" assemblage combining late Early Bronze and early Middle Bronze traits as recognized in the Euphrates valley at Tell Kabir level 6, Sweyhat phases 5-6, and Hadidi MB I<sup>39</sup>. If such an assemblage is an accurate reflection of an EB-MB transitional period and does not represent ceramics from mixed contexts, its absence at Umm el-Marra may imply an abandonment of the site in the EB-MB transitional period<sup>40</sup>.

#### Evidence for a Reduction in Occupied Site Area

In addition to a possible gap in site occupation, it has been proposed that there was a reduction in the occupied area at Umm el-Marra from EB IV to MB I<sup>41</sup>. In the Acropolis West, a sequence of EB IV phases followed by MB I (Umm el-Marra IIIId), and MB II (Umm el-Marra IIIa-c) strata was observed in the 1994-1997 excavations. In the Acropolis East, however, EB IVB occupation was succeeded by MB strata with pottery comparable to that of Acropolis West MB II. Therefore, MB I (Umm el-Marra sub-period IIIId) appeared to be missing in the Acropolis East, indicating an unoccupied zone in that part of the site in MB I. Further, excavations in the West Area A on the edge of the site in 1995-1997 had recovered strata with MB II pottery above EB remains, with little evidence of MB I ceramics.

In 1999, the earliest MB strata excavated in the Acropolis North included pottery comparable to sub-period IIIId, and thus MB I occupation was identified in that area<sup>42</sup>. A study of late EB and MB pottery from the Acropolis West, East and North by John Nichols<sup>43</sup> agreed with the previous assessment of MB occupation on the acropolis but recognized deposits with MB I pottery in one of the three Acropolis East trenches investigated (1314/3882).

In more recently excavated MB contexts on the Acropolis Center and areas beyond the acropolis, documentation of MB I will require quantitative analysis of the ceramics retrieved. Associated with the earliest MB phases in the Acropolis Center was the circular stone Monument 1 built above the EB elite mortuary complex; whether this is datable to MB I or early MB II remains to be determined, since the earliest MB pottery in this area evinces characteristics of both sub-periods IIIId and IIIa-c. Outside the acropolis, the soundings to virgin soil in West Area A (trench 1078/3872) and North Area B (trench 1135/4034) in 2006 revealed architectural phases with MB II pottery above deposits lacking architecture but containing MB sherds. Again, these earlier MB sherds included both IIIa-c and IIIId characteristics, requiring further analysis to determine if the associated contexts should be dated to MB I or early MB II. It is possible that MB I (IIIId) occupation is more extensive than originally proposed, but it is also possible that the earliest MB occupations on the Acropolis Center, West Area A, and North Area B, should be assigned to early MB II. The evidence for an

39) Porter, this volume ; Cooper 2006b : 23-6 (designated as Phase 6 in Cooper's Middle Euphrates EB chronology). Amarna phase III, Halawa phase Q3A, and Qara Quzaq II-3 might also belong to this horizon (Pons 2001 ; Hempelman 2005 ; Valdés Pereiro 2001 : figs. 9-11), as well as Afis IV-V in the Madekh region (Mazzoni and Felli, this volume). In a study of the EB-MB sequence of pottery from trench 1270/3936 in the Acropolis North at Umm el-Marra, H. Curvers identified some sherds from post-EB contexts that might be comparable to EB-MB transitional types. However, they are rare and derive from thin strata without associated architecture, possibly implying a transitory, small-scale habitation at the site immediately after the EB levels (Schwartz *et al.* 2003, 341 n. 62).

40) Such an assemblage would be best documented by the presence of complete vessels, since contexts containing EB and MB sherds without complete vessels could be interpreted either as EB-MB transitional or as an early MB phase with EB residual sherds originating in EB deposits. Unfortunately, complete vessels are scarce in Umm el-Marra IIIId strata. One may also note that Ebla, which demonstrates considerable architectural continuity between EB and MB and probably experienced no occupational hiatus, nevertheless has not produced an EB-MB transitional assemblage (Mazzoni and Felli, this volume).

Of as yet uncertain significance to the issue under discussion is the recovery of only EB type anthropomorphic clay figurines in MB I levels at Umm el-Marra (Petty 2004). MB II type figurines appear in MB II strata at Umm el-Marra, but MB I types as defined in Marchetti's typology are missing at the site (Marchetti 2001).

41) Schwartz *et al.* 2000 : 425.

42) Schwartz *et al.* 2003 : 342.

43) Nichols 2004.

MB I occupation of reduced size at Umm el-Marra is not as robust as it seemed earlier, but further study is necessary to resolve the issue.

### MIDDLE BRONZE II OCCUPATION

It is clear that MB II (Umm el-Marra IIIa-c) was an era of major occupation and activity at Umm el-Marra. Evidence of this sub-period was obtained in all trenches excavated below Late Bronze contexts. Major features include a city wall built above two glacis constructions identified in the West Area A and Northwest Area A, houses built against the city wall (Northwest Area A), a north-west city gate with several phases, one of which was burned (Northwest Area B, excavated 2006), a broad pebble-paved street (North Area B), and mudbrick fortifications and a glacis associated with the northeast gate<sup>44</sup>. On the acropolis, an enclosure wall was identified, inside of which was domestic architecture, evidence of craft activity, and the large circular stone Monument 1.

Ceramically, MB II at Umm el-Marra (sub-period IIIa-c) is comparable to Mardikh IIIB, Hammam et-Turkman VIIB-C, and Alalakh IX-VII. Frequent types include "shoulder" jars or goblets with tall necks and pronounced shoulders<sup>45</sup>, tall beakers with low carination<sup>46</sup>, wide-mouthed, tall-necked jars often with corrugation or painting<sup>47</sup>, jars with collared, slightly grooved rims<sup>48</sup>, tall-necked jugs with grooved rims<sup>49</sup>, large kraters with everted rims that are grooved on top<sup>50</sup>, small carinated or round-bodied goblets with short everted rims or tall necks<sup>51</sup>, carinated shallow bowls<sup>52</sup>, and shallow bowls with inturned rims<sup>53</sup>. Cooking vessels primarily have collared rims<sup>54</sup> or short everted rims<sup>55</sup>.

### SURVEY DATA

A survey of the area north of the Jabbul lake conducted by the Umm el-Marra project team in 1996 recognized 47 mid-late EB sites and 33 MB sites (Fig. 5 and 6)<sup>56</sup>. Of the 47 mid-late EB sites, 25 were abandoned by the end of the period, while 22 showed signs of occupation in MB. Most of the deserted EB sites were located in the drier, eastern part of the surveyed region, whose sedentary occupation was much decreased in MB. Since mid-late EB (*ca.* 2600-2000) is a longer period than MB (*ca.* 2000-1600), a smaller number of MB sites need not imply a demographic decline<sup>57</sup>, but a drop from 47 to 33 sites is more drastic than would be expected and indicates a shift in the scale and character of sedentary occupation. If a rough preliminary estimate of settled hectarage can be credited, the decrease in the number of sites (30%, from 47 to 33) was more severe than the reduction in total area occupied (20%, from 106 to 85 hectares), indicating that the abandoned sites tended to be small and that the depopulation of the eastern zone was more significant than a massive downturn in sedentary population. The decrease in the number of occupied sites continues later in the Second

44) Schwartz *et al.* 2000 : 429-30 ; Tefnin 1983.

45) Curvers and Schwartz 1997 : Fig. 23: 10 ; Schwartz *et al.* 2003, Fig. 30: 4.

46) Curvers and Schwartz 1997 : Fig. 23: 17 ; Schwartz *et al.* 2003, Fig. 29: 2.

47) Curvers and Schwartz 1997 : Fig. 23: 15 ; Schwartz *et al.* 2003, Fig. 29: 3, Fig. 30: 1-3.

48) Curvers and Schwartz 1997 : Fig. 23: 11.

49) Curvers and Schwartz 1997 : Fig. 23: 2, 18.

50) Curvers and Schwartz 1997 : Fig. 24: 3, 8-9, 18-19 ; Schwartz *et al.* 2003, Fig. 29: 7.

51) Curvers and Schwartz 1997 : Fig. 23: 4-9 ; Schwartz *et al.* 2003, Fig. 29: 4.

52) Curvers and Schwartz 1997 : Fig. 24: 13-14.

53) Curvers and Schwartz 1997 : Fig. 24: 5-6 ; Schwartz *et al.* 2003, Fig. 29: 1.

54) Curvers and Schwartz 1997 : Fig. 24: 7 ; Schwartz *et al.* 2003, Fig. 29: 9-10.

55) Curvers and Schwartz 1997 : Fig. 24: 15.

56) Schwartz *et al.* 2000. Note that Fig. 6 is a corrected version of figure 21 in Schwartz *et al.* 2000, which erroneously added two sites to the western part of the MB map.

57) The longer the period, the more site abandonments and new foundations might be expected within that time span (Weiss 1977 ; Dewar 1991).

Millennium, with a drop from 33 MB to 11 LB sites in the surveyed area<sup>58</sup>. A similar pattern of a steady diminution of sedentism throughout the Second Millennium has also been identified in numerous other parts of Syria and Mesopotamia<sup>59</sup>. Whether this decline in sedentism can be linked to collapse or crisis at the end of the Third Millennium remains to be elucidated, but the process must have begun in the EB period in the Jabbul, since a large number of sites are abandoned prior to the employment of MB pottery.

Of the 33 MB sites identified in the Jabbul survey, only four had sherds identifiable as MB I, which indicated a particularly severe drop in sedentary occupation in the latter phase, but the difficulties in distinguishing MB I from MB II discussed above render this conclusion highly tentative<sup>60</sup>. At the same time, 22 of the 33 MB sites were founded atop tells that had been occupied in EB. This could be interpreted in one of two ways: either our assessment of MB I occupation was grossly underestimated, with a strong pattern of continuity between EB and MB, or abandoned EB tells were a popular site for MB II reoccupation. Deserted tells characteristically serve as loci for reoccupation throughout the Middle East, given their conspicuousness and the environmental or strategic advantages of their location<sup>61</sup>.

In any case, it seems clear that the drier, eastern part of the survey region was relatively deserted in MB after a period of profuse settlement in EB. If the area received less rainfall than regions to the West, as implied by current climatic data, a decline in precipitation in the late Third Millennium as proposed by Weiss and his colleagues<sup>62</sup> may have rendered the region less amenable to agricultural exploitation. Alternatively, a collapse of political or economic systems by the end of the Third Millennium, with or without an accompanying climatic crisis, may also have played an influential role in the depopulation of the eastern area. The exploitation of relatively marginal regions in EB IV may have been sponsored by large-scale institutions interested in agricultural maximization<sup>63</sup>, but once those institutions disintegrated or suffered a reduction in power and resources, such projects may have suffered. Whatever the reason for the decrease in occupation in the eastern Jabbul, it is synchronous with an intensified period of exploitation of the wild species of the steppe, as evinced by the faunal evidence of hunted onagers from MB Umm el-Marra<sup>64</sup>.

### ECOFACTUAL ANALYSIS

Faunal and archaeobotanical analyses of data from Umm el-Marra have revealed evidence of both continuity and change between EB to MB. Whether the changes are to be understood as evidence for, or a consequence of, a crisis or collapse at the end of EB remains to be fully determined. In the faunal data, sheep and goat persist as the main domesticates from EB to MB, but goat attain a new importance in MB I. While equids were already frequent in EB, a significant increase in equid exploitation is observed in MB which has been interpreted as a major concentration on the hunting of onagers. Jill Weber has posited that this practice developed into a large-scale enterprise devoted to the production of leather for consumption in an expanded commodities sphere<sup>65</sup>. Gazelle also increased in MB, and the rise in dogs may have been a result of their employment by humans in

58) A rough preliminary estimate of site sizes shows a decline of 34% in total occupied site area from MB to LB (from 85 to 56 hectares), as opposed to the 67% drop in the number of occupied sites (from 33 to 11). The persistent occupation of Umm el-Marra, many times larger than any of the other sites in the survey region, is partly responsible for the substantial difference between the two percentages, but it is also clear that the sites that survived into LB tended to be among the largest in the region.

59) Wilkinson 2003.

60) Nichols' PhD thesis (2004) noted that all MB sites from the survey had at least one rim sherd of a type well-represented in the MB I levels at Umm el-Marra, but such types tended to be frequent in MB II levels as well.

61) Wilkinson 2003 : 108.

62) Weiss *et al.* 1993.

63) See Geyer and Calvet (1991) on the extensive occupation of the dry steppe of western Syria in EB IV, as well as Castel (this volume).

64) Schwartz *et al.* 2000 ; Nichols and Weber 2006.

65) Weber 2006 ; Nichols and Weber 2006 ; Schwartz *et al.* 2000 : 435-7.

continuity  
beg in EB  
of site  
abandonment



hunting expeditions. It is clear that a heightened exploitation of the steppe for hunting wild species is a marked innovation of the MB period at Umm el-Marra.

Previous archaeobotanical analyses revealed the prevalence of two-row barley and, to a lesser extent, bread wheat from EB and MB contexts at Umm el-Marra<sup>66</sup>. Small quantities of pulses were also identified, as well as fig, grape and olive<sup>67</sup>. At the same time, evidence of change was revealed in the decreased ratio of wild seeds relative to cultigens, which suggested a shift from pasturing domesticated animals in the steppe in EB to a focus on growing fodder for herds in MB.

#### New Archaeobotanical Data<sup>68</sup>

Here we supplement previous archaeobotanical results with data derived from research conducted on eleven samples excavated between 1999 and 2002. The samples were selected for analysis based on the quantity of charred remains and date, it being our intention to concentrate on the under-represented periods of EB and MB I. In the following report, information from the previously published samples is integrated into the discussion. Most of the seven Early Bronze Age (EB) samples derive from ashy deposits, and three of the four Middle Bronze Age I (MB I) samples come from post-abandonment (?) room fill (Table 2).

Table 2 : Inventory and provenience of samples analyzed in this report.

Square	Feature	Date exc.	Date	Area	Description
1276/3928	304	6/13/00	EB II (period VI early)	Acropolis North	ashy layer
1276/3930	308	6/4/00	EB III (period VI late)	Acropolis North	ashy layer
1316/3870	304	5/24/99	EB III (period VI late)	Acropolis East	ashy debris
1284/3900	205/206	7/5/00	EB IVA (period V)	Acropolis Center	ash layer
1232/3872	414	7/3/00	EB IVB (period IV)	Acropolis West	ashy lens associated with thick lime plaster surface
1264/3900	Room 3-004	7/4/02	EB IVB (period IV)	Acropolis Center	ashy pit fill
1266/3930	106	6/21/00	EB IV (periods V-IV)	Acropolis North	ash layer
1232/3856	206	7/2/99	MB I (period IIIId)	Acropolis West	room fill
1228/3854	207	7/3/99	MB I (period IIIId)	Acropolis West	room fill
1232/3856	208	7/5/99	MB I (period IIIId)	Acropolis West	room fill
1232/3866	410	6/26/00	MB I (period IIIId)	Acropolis West	ashy debris

#### The Taxa

The earlier reports provide more detailed discussion of the taxa, while the present study notes the addition of several previously unrecorded taxa to the assemblage (Table 3).

Cultigens and other economic plants:

The two main cereal crops are bread or hard wheat (*Triticum aestivum* or *T. durum*) and barley (*Hordeum vulgare*). In addition to two-row barley, the new samples include remains of six-row barley in the form of rachis fragments and some twisted grains. Barley rachis fragments still outnumber those of wheat, and einkorn or emmer (*Triticum monococcum* or *T. dicoccum*) is represented only by spikelet forks.

Other cultigens include lentil (*Lens*), fig (*Ficus*), olive (*Olea europaea*), grape (*Vitis vinifera*) and safflower (*Carthamus cf. tinctoria*). For fuller discussion, see the earlier reports.

66) Miller 1998 ; Schwartz *et al.* 2000 : 438-447.

67) While Miller (in Schwartz *et al.* 2000 : 442) suggested that olive and grape were imported from elsewhere, Rigot (2003) argues for their cultivation in the Jabbul.

68) The following data are derived from Miller (2003), available on request.

Table 3 : Previously unreported taxa\*.

year excavated	1276	1276	1316	1284	1232	1264	1266	1232	1228	1232	1232
	3928	3930	3870	3900	3872	3900	3930	3856	3854	3856	3866
	304	308	304	205/206	414	3-004	106	206	207	208	410
	2000	2000	1999	2000	2000	2002	2000	1999	1999	1999	2000
	EB	EB	EB	EB	EB	EB	EB	MB I	MB I	MB I	MB I
volume (zanbils)	0.75	0.33	1	1?	1	1?	1	1	1	1	1
est. volume (liters)	12	5	15	15	15	15	15	15	15	15	15
charcoal > 2mm (g)	0	+	1.17	0.35	0.05	0.7	0.1	0.26	0.26	0.92	0.16
seed > 2mm (g)	0.14	0.04	0.27	1.23	0.68	0.15	0.34	0.31	0.31	0.50	1
rachis etc. > 2mm (g)	+	0.03	0	0.05	0.01	+	0.02	0.03	0.01	0.05	0.03
charred density (g/liter)	0.01	0.01	0.10	0.11	0.05	0.06	0.03	0.04	0.04	0.10	0.08
wild seed/liter (g/g)	44	26	15	105	58	23	19	6	5	12	20
seed/charcoal (g/g)	n/c	n/c	0.23	3.51	13.60	0.21	3.40	1.19	1.19	0.54	6.25
weed seed (#)	523	130	221	1571	870	345	286	97	73	175	306
wild seed/charcoal (#/g)	n/c	n/c	189	4489	17400	493	2860	373	281	190	1913
wild/cereal (#/g)	2753	13000	650	1257	879	1643	477	237	92	307	247
Food and cultigen											
Hordeum (g)	0.12	0.01	0.17	0.78	0.62	0.10	0.25	0.22	0.20	0.31	0.91
Triticum aestivum/durum (g)	-	-	-	0.04	-	0.01	-	0.02	+	-	0.03
Triticum sp. (g)	0.02	+	-	0.04	0.05	-	-	-	+	0.02	0.01
Cereal	0.05	-	0.17	0.39	0.32	0.10	0.35	0.17	0.59	0.24	0.29
Lens	-	-	-	2	1	2	-	-	-	-	-
Pulse	-	-	-	-	0.01	-	-	-	-	-	-
Ficus	-	-	6	7	-	6	12	-	-	-	1
Olea	-	-	-	1	-	-	1	-	-	-	-
Vitis	-	-	-	1	2	1	-	-	-	-	-
Carthamus cf. tinctoria	-	1	-	1	-	-	1	-	-	-	-
Wild and weedy											
cf. Anthriscus	-	-	-	5	10	-	-	-	-	1	12
Anthriscus-like short	-	-	-	4	8	-	-	-	-	-	-
Bupleurum subovatum-type	-	-	-	-	-	-	-	1	-	-	-
Torilis "leptophylla"	-	-	-	-	1	-	-	-	-	-	-
Umm.Apiaceae-1	-	-	-	-	-	1	-	-	-	-	-
cf. Achillea	1	-	-	-	-	-	-	-	-	-	-
Artemisia	-	-	-	-	-	3	1	-	-	-	-
Centaurea	5	-	1	4	1	4	1	-	-	-	-
Umm.Asteraceae -1	-	-	-	10	1	1	9	-	-	1	-
Umm.Asteraceae -3	1	3	4	3	8	-	1	-	-	3	-
Umm.Asteraceae -4	-	-	3	8	-	-	13	-	-	-	-
Umm.Asteraceae -4.1	-	-	-	4	-	-	-	-	-	1	-
Umm.Asteraceae -5	5	-	-	-	-	-	-	-	-	-	-
Umm.Asteraceae -6	-	-	-	1	-	-	8	-	-	-	-
Umm.Asteraceae -7	-	-	-	-	-	-	1	-	-	-	-
Asteraceae, various	-	-	-	7	-	-	-	-	-	1	-
Arnebia decumbens, burnt	-	-	-	1	-	-	4	-	4	-	-
A. linearifolia, burnt	-	-	-	3	-	-	-	-	-	-	-
Heliotropium	4	12	-	-	-	-	-	-	-	-	-
Brassica napa-type	-	-	-	1	-	-	-	-	-	-	-
cf. "Matthiola"	1	-	-	-	2	-	-	-	1	-	-
Umm.Brassicaceae-1	-	-	-	-	-	-	1	-	-	-	-
Umm.Brassicaceae-2	-	-	-	-	7	-	-	-	-	-	1
Umm.Brassicaceae-6	-	-	-	-	-	-	-	-	-	1	-
Brassicaceae, various	2	1	-	2	-	-	2	-	-	-	-
Dianthus/Petrorragia-type	-	-	-	-	1	-	-	-	-	-	-

\*) See Schwartz *et al.* 2000 : 438-447.



**Table 4 : Significant taxa, percent of assemblage by phase\***

No. samples No. seeds	EB 9 6568	MB I 6 998	MB II 7 1275	LB 7 2346
Caryophyllaceae (as a group)	5.4%	1.0%	1.7%	11.6%
Fabaceae (as a group**)	13.2%	15.7%	9.1%	19.8%
Poaceae (as a group***)	34.7%	58.2%	56.8%	29.5%
Individual numerous genera				
<i>Astragalus</i>	5.1%	6.3%	2.7%	4.2%
<i>Trigonella</i>	8.4%	3.4%	4.2%	10.4%
<i>Eremopyrum</i>	7.0%	24.9%	17.2%	11.5%
<i>Phleum/Eragrostis</i>	3.7%	19.1%	14.6%	0.6%

\*) Taxa with more than 500 items counted in the Umm el-Marra assemblage. Seven analyzed samples are not included here due to the small amount of charcoal present (two from EB, four from LB). One LB sample consisted of pure charcoal and is also excluded.

\*\*\*) Includes *Astragalus* and *Trigonella*

\*\*\*\*) Includes *Eremopyrum* and *Phleum/Eragrostis*

seeds, so it is not possible to reliably assess changes over time. Examination of the distribution of the most numerous types—those with more than 500 exemplars (families combined) are unfortunately not that interpretable (Table 4). With the possible exception of *Trigonella*, which is most likely to have grown on uncultivated steppe, the taxa listed are fairly broad in habit and ecological requirements. For example, the most numerous member of the Caryophyllaceae, *Gypsophila*, includes some species that grow wild on the steppe and others that are common in fields. *Astragalus*, too, has many species that grow in a variety of habitats. Poaceae (the grasses in general) is a very broad category; most are plants of open ground, but it is hard to generalize beyond that. The two grasses, *Eremopyrum* and *Phleum/Eragrostis*-type, too, could be either field weeds or wild plants. It may be significant that at the site of Hajji Ibrahim near Swayhat, *Eremopyrum* seems to be associated with cultivated grain. Willem van Zeist<sup>69</sup>, too, considers *Eremopyrum* to be a likely field weed plant in Syria.

### Discussion

The following discussion incorporates the data from the samples analyzed from the 1999-2002 seasons with those previously reported. Relatively few samples per phase have been analyzed, so conclusions are tentative at best. For purposes of this discussion, we assume that most of the seeds from ordinary occupation debris derive from dung fuel. The one unusual deposit (1232/3872-414) may not be ordinary trash.

#### Vegetation:

We use the ratio of seeds to charcoal as a rough way to assess the state of the vegetation near the site—insofar as seeds are from dung fuel, the seed:charcoal ratio (s/c) can be used to track changes in the arboreal vegetation<sup>70</sup>. Table 5 does not show a straight line trend, but if one omits the two outliers<sup>71</sup>, which have unusually high cereal proportions relative to charcoal, there is an increase in this ratio over time. That is, there appears to be a long-term trend toward deforestation, similar to the one documented for sites along the Euphrates<sup>72</sup>.

69) Van Zeist 1993 : 504.

70) Miller 1998.

71) EB sample 1232/3872-414, with little charcoal > 2 mm and a lot of seed material, has an unusually high value of 13.60 for seed/charcoal. MB II sample 1320/3866-010 is an ashy pit.

72) Miller 1997.

#### Wild and weedy plants:

Several types new to Umm el-Marra have been identified in the samples reported here. They include: cf. *Anthriscus*, *Bupleurum subovatum*-type, "*Torilis leptophylla*" type=Umm. Apiaceae 3?, cf. *Achillea*; *Brassica napa*, "cf. *Matthiola*", *Eleocharis*, *Scirpus*, *Scorpiurus*, *Ajuga*, *Avena*, cf. *Echinaria*, *Stipa*, cf. *Taeniatherum*, *Portulaca*, *Valerianella coronata*-type. Also, *Helianthemum* [Umm.unknown-4], a common plant of the steppe, had been unrecognized. In addition, evidence for cf. *Alhagi* now includes seeds as well as pod fragments.

#### Distribution over time:

Most taxa are represented by few

The high absolute values of the seed:charcoal ratio at Umm el-Marra are, however, surprising. Umm el-Marra is much closer to the wooded uplands near Aleppo than Swayhat, yet the seed:charcoal ratios are higher than those from contemporary levels at the latter site. The most likely explanation for this apparent anomaly: the people of Swayhat (and the earlier Euphrates settlements at Hacinebi and Kurban Höyük) had ready access to willow and/or poplar, fast-growing riparian types, while the residents of Umm el-Marra had no such riverine environments in their vicinity. The Jabbul salt lake would not have had much woody vegetation along its shore.

#### Agricultural economy:

Most of the identified cereal grains and rachis fragments are barley, and most of the barley is probably the two-row type. Barley would have been important both for animal fodder and human food<sup>73</sup>. No new food or cultigen taxa were recognized in the eleven samples analyzed from the 1999-2002 seasons. There were some new wild and weedy types—plants of open ground, but they represent a small proportion of the total assemblage.

Along the Euphrates, insofar as the wild:cereal ratio reflects foddering practices, higher values suggested an emphasis on herding, with animals sent out to graze, and lower values represent an emphasis on farming, with more cultivated fodder being used<sup>74</sup>. In particular, at Kurban Höyük, higher proportions of sheep-goat relative to cattle-pig were associated with higher wild: cereal ratios. Conversely, for times when the assemblage has a greater emphasis on cattle and pig, animals that need more surface water and are more likely to live in settlements, cultivated fodder is relatively more important than grazing. Presumably, where rainfall agriculture is most secure (Kurban Höyük), the wild:cereal ratio is lower than where it is least secure (Swayhat) (Table 5); one might expect

**Table 5 : Archaeobotanical comparisons between Umm el-Marra and other sites\***

	no. samples	seed/charcoal (g/g) [1]	wild/cereal (no./g) [2]	barley % (total g) [3]
Umm el-Marra				
LB	7	3.81	782	88 (3.46)
MB II	7	3.84 (2.21)	476	85 (1.99)
MB I	6	2.00	416	94 (2.15)
EB	9	2.69 (1.33)	1175	93 (1.21)
Swayhat				
EB/MB	17	1.13	(5465)	96 (4.56)
Kurban Höyük				
EB/MB	6	0.48	(114)	78 (0.18)
EB (Late 3rd)	62	0.49	(242)	68 (6.03)
EB (Early 3rd)	32	0.37	(158)	45 (9.11)
Chalcolithic	29	0.34	(118)	57 (2.81)
Hacinebi				
Chalcolithic	23	0.46	501	73 (2.77)

\*) Seven analyzed samples from Umm el-Marra are not included here due to the small amount of charcoal present (two from EB, four from LB). One LB sample consisted of pure charcoal and is also excluded.

1) seed/charcoal: value in parentheses excludes outliers—EB sample 1232/3872-414 and MB II sample 1320/3866-010, an ashy pit.

2) wild/cereal: Swayhat values in parentheses excludes three samples (unmeasurable cereal, outlier, jar); Kurban values in parentheses exclude samples with no cereal (2 EB/MB; 11 Late 3rd; 1 Early 3rd, 2 Chalcolithic); effect is to underestimate the values, but those samples have few seeds of any type.

3) % of barley + wheat by weight; total weight in parentheses.

73) In a Syrian dryland agricultural village, barley production "was significantly correlated with the number of livestock" (Tully 1984 : 17). However, note that barley is commonly attested in texts and in primary contexts observed archaeologically (e.g. Schwartz et al. 2003 : 348) as important for human consumption as well.

74) Miller 1997.

**Table 6 : Faunal remains from Umm el-Marra (Weber 2006 and Jill Weber, pers. comm. 12/14/06)\*.**

Count (NISP)	EB	MB I	MB II	LB
sheep/goat	569	205	2199	945
Gazelle	43	7	249	185
Pig	38	10	38	34
Cattle	155	34	257	131
Equid	173	141	1223	515
Dog	27	13	130	42
NISP(%)	EB	MB I	MB II	LB
Sheep	56 (58 %)	10 (42 %)	219 (39 %)	77 (52 %)
Goat	41 (42 %)	14 (58 %)	338 (61 %)	70 (48 %)
Percent (NISP)	EB	MB I	MB II	LB
sheep (est.)	0.33	0.21	0.21	0.27
goat (est.)	0.24	0.29	0.33	0.24
gazelle	0.04	0.02	0.06	0.10
pig	0.04	0.02	0.01	0.02
cattle	0.15	0.08	0.06	0.07
equid	0.17	0.34	0.31	0.28
dog	0.02	0.03	0.03	0.02

\*) Includes only main animals presumed to be food animals; excludes sheep/goat/gazelle; bovid/cervid; deer; fox; hare; bird; reptile; large, medium, and small mammals; and unidentified mammal. Percent of sheep and goat estimated from percent of identified specimens. Note that EB equid counts exclude the skeletons from the burial complex.

The introduction of hunting as a significant source of meat (along with its contribution to leather production) in the Middle Bronze Age complicates this picture considerably. The data for the primary food animals show relatively low proportions of cattle, pig, and sheep during the Middle Bronze Age, because hunted equids and goat take on much greater importance (Table 6)<sup>76</sup>. The wild to cereal ratio is also lowest in the Middle Bronze Age deposits. If it is reasonable to infer that the wild:cereal ratio reflects animal diet, we would expect it to be highest when the economy is oriented toward steppe grazing and lowest when the economy is oriented toward rainfall agriculture. If it is also reasonable to infer that the economy was oriented toward the steppe when equid and goat bones dominate the assemblage, we would expect the wild:cereal ratio to follow the proportion of equid and goat bone. Yet the opposite appears to be the case: it is lowest in the Middle Bronze Age and rises and falls along with the proportions of cattle, pig, and sheep bone. With such small numbers of samples, one cannot discount the effect of chance deposition and recovery, but if the patterns hold up, we can propose at least two plausible explanations.

First, perhaps the Early and Late Bronze Age economies were indeed steppe-oriented but emphasized meat production for trade. In that case, animals on the hoof would leave their dung behind (high wild: cereal) but not their bones (low proportions of grazers). Second, perhaps during the Middle Bronze Age, the adoption of hunting led to a shift in seasonal land use practice, where winter-grazing on the steppe and spring-grazing on field stubble might depress the wild:cereal value. In particular, hunting might be associated with shifts in the seasonal allocation or availability of labor. Low wild:cereal ratios would result from pasturing sheep and goat on perennial steppe grasses dur-

there to be some correlation between feeding practices and herding practices. In all phases at Umm el-Marra, the values of the wild:cereal ratio are intermediate between Kurban and Sweyhat. This suggests that the agropastoral economy at Umm el-Marra (*i.e.* emphasis on farming vs. herding) was balanced at a point somewhere between the two Euphrates sites. Correspondingly, the present-day annual precipitation at Umm el-Marra is somewhat higher than at Sweyhat and less than at Kurban Höyük<sup>75</sup>.

The values of the botanical and faunal data are based on relatively small sample sizes, so trends are sometimes more useful than absolute numbers for discovering patterns (Table 7). As expected, *Trigonella* and the wild:cereal ratio follow the same pattern (higher amounts are indicators of grazing). *Eremopyrum*, and the grasses in general, show the opposite trend (*i.e.* they seem to be associated with farming). For Umm el-Marra, this pattern suggests that herding was most important at the beginning and end of the sequence, with farming more important in the middle. If one considers only the domesticated animals associated with herding and farming (sheep, goat, cattle and pig), there are no clear associations between fodder and animal taxon.

75) Wilkinson 2003 : Fig. 6.2.

76) Nichols and Weber 2006 ; Weber 2006.

**Table 7 : Summary of trends.**

	EB to MB I	MB I to MB II	MB II to LB
Wild: cereal	-	+	+
Caryophyllaceae	-	+	+
Fabaceae	-	-	+
Poaceae	+	-	-
<i>Astragalus</i>	+	-	+
<i>Trigonella</i>	-	+	+
<i>Eremopyrum</i>	+	-	-
<i>Phleum/Eragrostis</i>	+	-	-
Sheep/goat	-	+	-
Sheep	-	+/-	+
Goat	+	+	-
Cattle, pig	-	-	+
Equid	+	+	-

occurred independently of environmental change or as a result of them; or in spite of population and cultural shifts or because of them<sup>78</sup>.

## CONCLUSIONS

This review has shown that our current understanding of the transition from the Early to Middle Bronze periods at Umm el-Marra is often hampered by a relatively small sample of data or by the need for more detailed analysis, as in the case of the MB ceramic *corpora*. Bearing that *caveat* in mind, we may observe that our data reveal indications of significant socio-cultural, economic, and material culture change in the transition from EB to MB at Umm el-Marra. In some cases these changes might be understood in terms of crisis or collapse. At the same time, manifestations of cultural and economic continuity are also evident.

The most dramatic schism between the two periods, if borne out by subsequent research, would be the conclusion that Umm el-Marra experienced complete abandonment in the EB-MB transitional period. This scenario is suggested by comparison of the earliest Umm el-Marra MB pottery with the pottery sequences from other north Syrian sites, wherein the later MB I character of the Umm el-Marra IIIc ceramics and the absence of a "Transitional" assemblage at the site argue for an occupational hiatus. Also possible, while similarly requiring further study, is the recognition of a reduced occupation area when Umm el-Marra is inhabited in its earliest MB phases.

Socio-cultural change from EB to MB is also indicated and in some cases might be understood in terms of social or political decentralization. Most significantly, by the end of EB, the Umm el-Marra acropolis is no longer employed as a burial place for members of the elite, and the mortuary complex falls out of use. This may suggest the decline of the resident authorities or a centralized system of control by the end of EB; it also might indicate a change in the character or practices of such authority rather than a decrease in its power. Other cultural innovations include the proliferation of sub-floor child burials in MB houses, a rarity in EB, the apparently symbolic or ritual use of equid bones in MB house foundations<sup>79</sup>, an MB enclosure wall built around the acropolis in areas previously utilized for domestic architecture, and the construction of an unprecedented circular stone monumental platform in the center of the acropolis.

77) The onager "is an extremely alert and cautious animal... [they] sometimes graze close to herds of horses and flocks of sheep. At the same time, even when extremely thirsty, they will not go to water sources used by man and livestock" (Heptner *et al.* 1988 : 1029).

78) Tribal nomadic peoples mentioned in ancient texts, e.g. Amorites, may have followed different land use strategies than those practiced by the pre-existing population of the region - assuming that the Amorites were new arrivals.

79) Schwartz *et al.* 2003 : 345-6. Note, however, that the discovery of equid sacrificial installations in the EB elite mortuary complex indicates that the ritual significance of equids predated the MB period.

While not supplying direct evidence of collapse or crisis, economic change from EB to MB is nevertheless apparent in the faunal and archaeobotanical data. The Middle Bronze Age sees an intensified focus on the hunting of wild species, particularly onagers, a pursuit that appears to have been one of the major economic *foci* of the community in this period. Further, the archaeobotanical data suggest a change in animal foddering practices from EB to MB, with evidence for pasturing flocks on the steppe giving way to foddering the animals closer to home. Presumably the emphasis on hunting herds of onager and gazelle in the steppe resulted in modifications to seasonal land use practices and the gender- and age-based allocation of labor.

Nichols and Weber<sup>80</sup> have hypothesized that the broadening of local subsistence strategies to include a concentration on hunting in MB was the manifestation of a flexibility that allowed the people of Umm el-Marra to survive in a period of environmental or social stress. Cooper has made a similar argument for the communities in the Middle Euphrates, suggesting that less hierarchical social organizations than were characteristic for other regions, as well as flexible subsistence practices, helped to account for the resilience and eventual florescence of Middle Euphrates settlements in MB<sup>81</sup>.

Less archaeologically visible but also of likely significance were ethnic changes – that is, the emergence of the Amorites as members of new elites in the Middle Bronze period. Although difficult to confirm, evidence of ritual innovations at Umm el-Marra such as the inclusion of equid bones in house foundations or the appearance of sub-floor infant burials might indicate the presence of members of new ethnic groups at least partly responsible for the developments transpiring at Umm el-Marra in MB<sup>82</sup>. Nichols has posited that the flexibility in subsistence strategies noted above may have been associated with Amorites and with their successes in MB<sup>83</sup>.

Regionally, the decline of settlement in the eastern, drier part of the Jabbul from EB to MB also indicates significant modifications to previous ways of life that might be understood as symptoms of trouble in the environmental or socio-political realm. At the same time, major depopulation is not indicated in the Middle Bronze, given the scale of occupation in the West and the likely presence of pastoral nomadic groups. The overall decline in woody vegetation, for example, suggests ongoing human exploitation of the landscape.

While major changes transpired at Umm el-Marra and its environs during the transition from EB to MB, elements of continuity are also notable. Economic specialization, markedly characteristic of the EB IV period, persists in Middle Bronze I, observable in the continued production of wheelmade pottery, the new practice of producing cooking vessels on the wheel, and in the focus on onager exploitation. Some continuity in the use of space is also apparent: although the Early Bronze mortuary complex fell out of use by the end of the Third Millennium, a monumental circular stone platform (Monument 1) was built on top of it in MB, revealing that the special character of this part of the site was still recognized. Similarly, when the fortifications of the site were revitalized in MB with glacis constructions and a city wall, they were erected above the earlier EB fortifications, duplicating the dimensions and configuration of the EB community. While the changes marking the advent of the Middle Bronze Age were of undoubted significance, some of the fundamental ideas, institutions and lifeways of the Early Bronze Age had not been forgotten and no doubt played a significant role in the creation of the new kind of society that emerged in the early Second Millennium B.C.

80) Nichols and Weber 2006.

81) Cooper 2006a.

82) Nichols and Weber 2006. Unfortunately, it is not at all clear if Amorites were newly resident in the region in MB or had been present all along, acquiring new prominence and conspicuousness due to the political success of some of their members.

83) Nichols 2004.

## BIBLIOGRAPHY

- Akkermans, P. and G. M. Schwartz  
 – 2003 : *The Archaeology of Syria : From Complex Hunter-Gatherers to Early Urban Societies (ca. 16,000-300 B.C.* Cambridge University Press, Cambridge.
- Bagh, T.  
 – 2003 : "The Relationship Between Levantine Painted Ware, Syro/Cilician Ware and Khabur Ware and the Chronological Implications", in M. Bietak (ed.), *The Synchronization of Civilisations in the Eastern Mediterranean in the Second Millennium B.C. II*, Verlag der Österreichischen Akademie der Wissenschaften, Vienna : 219-37.
- Cooper, L.  
 – 1997 : *The Middle Bronze Age of the Euphrates Valley, Syria : Chronology, Regional Interaction and Cultural Exchange*. Ph.D. dissertation, University of Toronto.  
 – 2006a : "The Demise and Regeneration of Bronze Age Urban Centers in Middle Bronze Age Syria", in G. Schwartz and J. Nichols (eds.), *After Collapse: The Regeneration of Complex Societies*, University of Arizona Press, Tucson : 18-37  
 – 2006b : *Early Urbanism on the Syrian Euphrates*, Routledge, London.
- Curvers, H. H.  
 – 1991 : *Bronze Age Society in the Balikh Drainage (Syria)*. Ph.D. Dissertation, University of Amsterdam.
- Curvers, H. H. and G. M. Schwartz  
 – 1997 : "Umm el-Marra, a Bronze Age Urban Center in the Jabbul Plain, Western Syria", *American Journal of Archaeology* 101 : 201-39.
- Dewar, R. E.  
 – 1991 : "Incorporating Variation in Occupation Span into Settlement-Pattern Analysis", *American Antiquity* 56 : 604-20.
- Dornemann, R.  
 – 1992 : "Early Second Millennium Ceramic Parallels between Tell Hadidi-Azu and Mari", in G. Young (ed.), *Mari in Retrospect : Fifty Years of Mari and Mari Studies*, Eisenbrauns, Winona Lake : 77-112.
- Finkbeiner, U. and F. Sakal  
 – 2003 : "Emar 2002 - Bericht über die 5. Kampagne der syrisch-deutschen Ausgrabungen". *Baghdader Mitteilungen* 34 : 10-99.
- Fugmann, E.  
 – 1958 : *L'architecture des périodes pré-Hellénistiques. Hama : fouilles et recherches, 1931-1938 v. 2, pt. I*, Nationalmuseet, Copenhagen.
- Geyer, B. and Y. Calvet  
 – 2001 : "Les steppes arides de la Syrie du Nord au Bronze ancien ou 'la première conquête de l'est'", in B. Geyer (ed.), *Conquête de la Steppe et appropriation des terres sur les marges arides du Croissant fertile*, Maison de l'Orient, Lyon : 55-68.
- Hempelmann, R.  
 – 2005 : *Die bronzezeitliche Keramik von Tell Halawa A*. Saarbrücker Druckerei und Verlag, Saarbrücken.
- Heptner, V.G., A.A. Nasimovich and A.G. Bannikov  
 – 1988 : *Mammals of the Soviet Union*, vol. 1. Smithsonian Institution Libraries and the National Science Foundation, Washington, D.C.
- Kaschau, G.  
 – 1999 : *Lidar Höyük : die Keramik der Mittleren Bronzezeit*. Philipp von Zabern, Mainz.
- Marchetti, N.  
 – 2001 : *La coroplastica Eblaïta e siriana nel Bronzo Medio*. Università degli Studi di Roma "La Sapienza", Rome.
- Mason, R. B. and L. Cooper  
 – 1999 : "Petrographic Analysis of Bronze Age Pottery from Tell Hadidi, Syria". *Levant* 31 : 135-47.
- Matthiae, P.  
 – 1997 : "Ebla and Syria in the Middle Bronze Age", in E. Oren (ed.), *The Hyksos : New Historical and Archaeological Perspectives*, University Museum, Philadelphia : 379-414.
- Mazzoni, S.  
 – 2002 : "The Ancient Bronze Age Pottery Tradition in Northwestern Central Syria", in M. al-Maqdissi, V. Matoian, and C. Nicolle (eds.), *Céramique de l'Age du Bronze en Syrie, I*, Institut français d'archéologie du Proche-Orient, Beirut : 69-96.

- Miller, N. F.  
 - 1988 : "Ratios in Paleoethnobotanical Analysis", in C. Hastorf and V. Popper (eds.), *Current Paleoethnobotany*, University of Chicago Press, Chicago : 72-85.  
 - 1997 : "Farming and Herding along the Euphrates : Environmental Constraint and Cultural Choice (Fourth to Second Millennia B.C.)". *MASCA Research Papers in Science and Archaeology 14* : 123-132.  
 - 1998 : "Plant Remains from Umm el-Marra, Syria, 1994-1997". *MASCA Ethnobotanical Laboratory Report 25*. On file, University of Pennsylvania Museum, Philadelphia.  
 - 2003 : "Plant Remains from Umm el-Marra, Syria: Report on Some Samples Excavated 1999-2002 and Summary". *MASCA Ethnobotanical Laboratory Report 35*. On file, University of Pennsylvania Museum, Philadelphia.  
 Nichols, J. J.  
 - 2004 : *Amorite Agro-Pastoralism and the Early-Middle Age Bronze Transition in Syria*, Ph.D. Dissertation, The Johns Hopkins University.  
 Nichols, J. J. and J. A. Weber  
 - 2006 : "Amorites, Onagers and Social Reorganization in Middle Bronze Age Syria", in G. Schwartz and J. Nichols (eds.), *After Collapse : The Regeneration of Complex Societies*, University of Arizona Press, Tucson : 38-57.  
 Nigro, L.  
 - 2002 : "The Middle Bronze Age Pottery Horizon of Northern Syria on the Basis of the Stratified Assemblages of Ebla and Hama", in M. al-Maqdissi, V. Matoian, and C. Nicolle (eds.), *Céramique de l'Âge du Bronze en Syrie, I*, IFAPO, Beirut : 97-128.  
 Peltenburg, E.  
 - 2000 : "From Nucleation to Dispersal. Late Third Millennium B.C. Settlement Pattern Transformations in the Near East and Aegean", in O. Rouault and M. Wäfler (eds.), *La Djéziré et l'Euphrate Syriens (Subartu VII)*, Brepols, Turnhout : 183-206  
 Petty, A.  
 - 2004 : *Bronze Age Figurines from Umm el-Marra, Syria : Chronology, Style, and Function*. Ph.D. Dissertation, The Johns Hopkins University.  
 Pinnock, F.  
 - 2005 : *La ceramica del palazzo settentrionale del Bronzo Medio II*. Università degli Studi di Roma "La Sapienza", Rome.  
 Rigot, J.-B.  
 - 2003 : "Environnement naturel et occupation du sol dans le bassin-versant du lac Jabbûl (Syrie du Nord) à l'Holocène". Ph.D. dissertation, Université Lumière Lyon 2.  
 Schwartz, G. M.  
 - 2006 : "From Collapse to Regeneration", in G. Schwartz and J. Nichols (eds.), *After Collapse : The Regeneration of Complex Societies*, University of Arizona Press, Tucson : 1-17.  
 - in press : "Status, Ideology and Memory in Third Millennium Syria : 'Royal' Tombs at Umm el-Marra", in N. Laneri (ed.), *Performing Death : Social Aspects of Mortuary Ritual*, Oriental Institute of the University of Chicago, Chicago.  
 Schwartz, G. M., H. H. Curvers, F. Gerritsen, J. MacCormack, N. F. Miller and J. A. Weber  
 - 2000 : "Excavation and Survey in the Jabbul Plain, Western Syria : the Umm el-Marra Project 1996-1997", *American Journal of Archaeology 104* : 419-462.  
 Schwartz, G. M., H. H. Curvers, S. S. Dunham and B. Stuart  
 - 2003 : "A Third-Millennium B.C. Elite Tomb and Other New Evidence from Tell Umm el-Marra, Syria", *American Journal of Archaeology 107* : 325-361.  
 Schwartz, G. M., H. H. Curvers, S. S. Dunham, B. Stuart and J. A. Weber  
 - 2006 : "A Third-Millennium B.C. Elite Mortuary Complex at Umm el-Marra, Syria : 2002 and 2004 Excavations", *American Journal of Archaeology 110* : 603-641.  
 Tefnin, R.  
 - 1983 : "Aperçu sur neuf campagnes de fouilles belges aux tells Abou Danné et Oumm el-Marra (1975-1983)". *Annales archéologiques arabes syriennes 33* : 141-50.  
 Tully, D.  
 - 1984 : *Land Use and Farmers' Strategies in al Bab : the Feasibility of Forage Legumes in Place of Fallow*. Research Report 12, International Center for Agricultural Research in the Dry Areas (ICARDA), Aleppo.

- Valdés Pereiro, C.  
 - 1994 : "La ceramica de la Edad del Bronce de Tell Qara Quzaq. Campaña de 1991", in G. del Olmo Lete (ed.), *Tell Qara Quzaq I. Campañas I-III (1989-1991)*, Editorial AUSA, Barcelona : 35-143.  
 - 2001 : "La ceramica de Tell Qara Quzaq. Campañas 1992-1994", in G. del Olmo Lete, J.-L. Montero Fenollós and C. Valdés Pereiro (eds.), *Tell Qara Quzaq II. Campañas IV-VI (1992-1994)*, Editorial AUSA, Barcelona : 119-254.  
 van Zeist, W.  
 - 1993 : "Archaeobotanical Evidence of the Bronze Age Field-Weed Flora of Northern Syria". *Festschrift Zoller. Dissertationes Botanicae 196* : 499-511.  
 Weber, J.  
 - 2006 : *Economic Developments of Urban Proportions : Animal Exploitation at Hajji Ibrahim/Tell es-Sweyhat and Tell Umm el-Marra, Northern Syria, during the Early and Middle Bronze Ages*. Ph.D. dissertation, University of Pennsylvania.  
 Weiss, H.  
 - 1977 : "Periodization, Population and Early State Formation in Khuzistan", in T.C. Young, Jr. and L. Levine (eds.), *Mountains and Lowlands : Essays in the Archaeology of Greater Mesopotamia*, Undena, Malibu : 347-69.  
 Weiss, H., M.-A. Courty, W. Wetterstrom, F. Guichard, L. Senior, R. Meadow and A. Curnow  
 - 1993 : "The Genesis and Collapse of Third Millennium North Mesopotamian Civilization". *Science 261* : 995-1004.  
 Wilkinson, T.J.  
 - 2003 : *Archaeological Landscapes of the Near East*. University of Arizona Press, Tucson.